



**FIELD** is an high quality electromechanical in-ground operator for residential use for swing gates with a leaf length of 3,5 m and weight leaf of 600 kg.

Lubrication with grease (oil bath optional)

Available in 3 versions: slow, fast and also with low voltage (24V) for maximum safety and intensive use.

Electronic limit switch and mecanichal stop in the carrying box.

Adjustable slow down in opening and closing with GATE control Board.

### MAIN PARTS NOMENCLATURE

- |                          |  |
|--------------------------|--|
| 1 Handle bar device      | 6 Foundation carrying box  |
| 2 Electric motor         | 7 Hole for water discharge   |
| 3 Cover fixation screw   | 8 Hole electric cable exit   |
| 4 Leaf device            | 9 Adjustable limit switch in closing   |
| 5 Counter-connecting rod | 10 Adjustable limit switch in opening<br>(Standard except for the Field 250) |

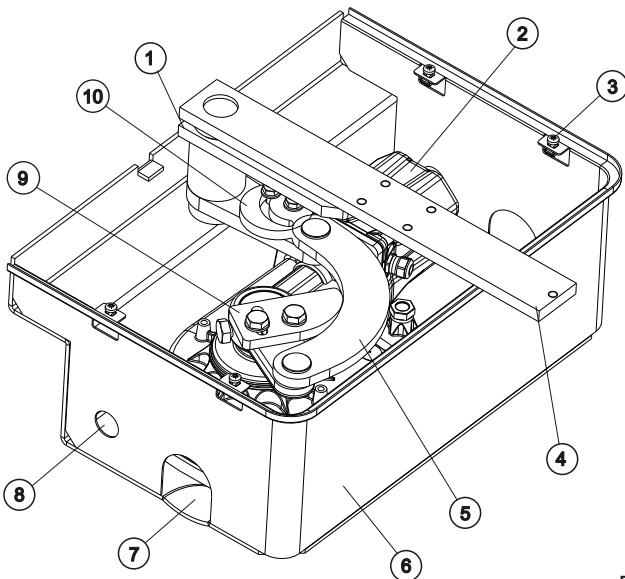

Fig. 1

### GRAPHIC FOR THE USE OF FIELD AND FIELD 24V

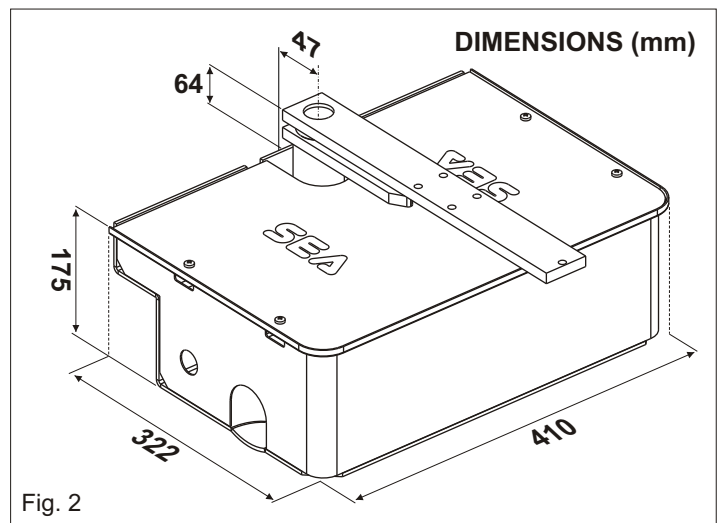
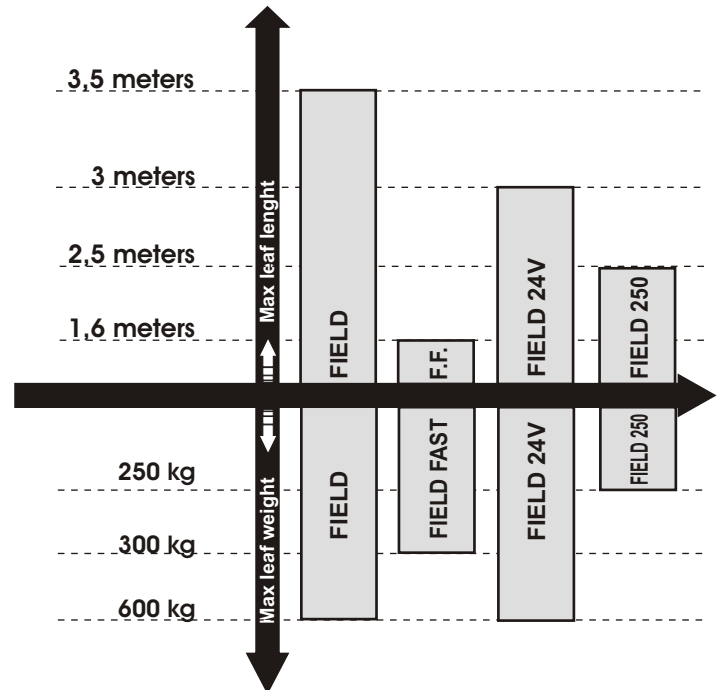

Fig. 2

TECHNICAL DATA	FIELD	FIELD Fast	FIELD 24V	FIELD 250
Power supply	230 V (± 5%) 50/60 Hz			
Absorbed Power	310W	380W	150W	280W
Frequency of use	20 cycles/h	20 cycles/h	50 cycles/h	15 cycles/h
Operating temperature	-20°C / +55°C			
Weight	12,5 kg	12,5 kg	13 kg	12 kg
Max leaf width	3,5 m	1,6 m	3 m	2,5 m
Opening degree	110° - 180° (optional)			
Time of 90° movem.	18 s	9 s	14/30 s	18 s
Protection class	IP67			
Starting capacitor	10 uF	12,5 uF	-	10 uF
Max torque	300 Nm	200 Nm	300 Nm	250 Nm
Max leaf weight	600 kg	300 kg	600 kg	250 kg

## 1. GATE ARRANGEMENT

You must do some checks on the gate to see if fitting a FIELD system is possible:

- A.** (Make sure that) the fixed and moving parts of the gate are strong and non-deformable;
- B.** the weight of each gate leaf must not exceed 300 kg (Field Fast), 800 kg (Field/Field 24V), 250 kg (Field 250);
- C.** the hinges and general structure must be in good condition and the gate must move smoothly throughout its travel;
- D.** the upper hinge alone is sufficient to install the unit; those which are unnecessary can be eliminated (the lower and that in the middle if exists);
- E.** in case of leaf length superior of 1,8 m and 150 kg of weight, it is recommended to fix to the ground a mechanical stop in closing (Fig. 3).

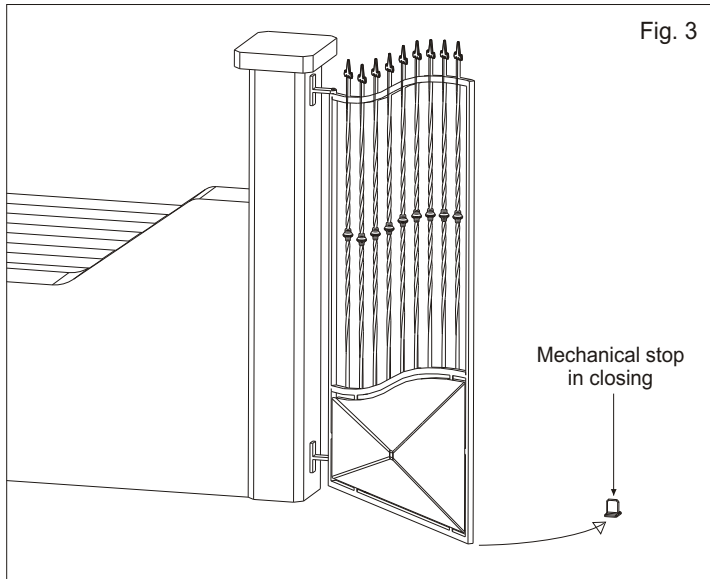

Fig. 3

## 2. CARRYING BOX INSTALLATION

2.1. The hole which contains the carrying box must have the approximate dimensions mentioned in Fig. 4.

For a correct placing, it is obligatory to follow closely the quote of 47 mm which corresponds to the minimum distance of the rotation axis from the pillar.

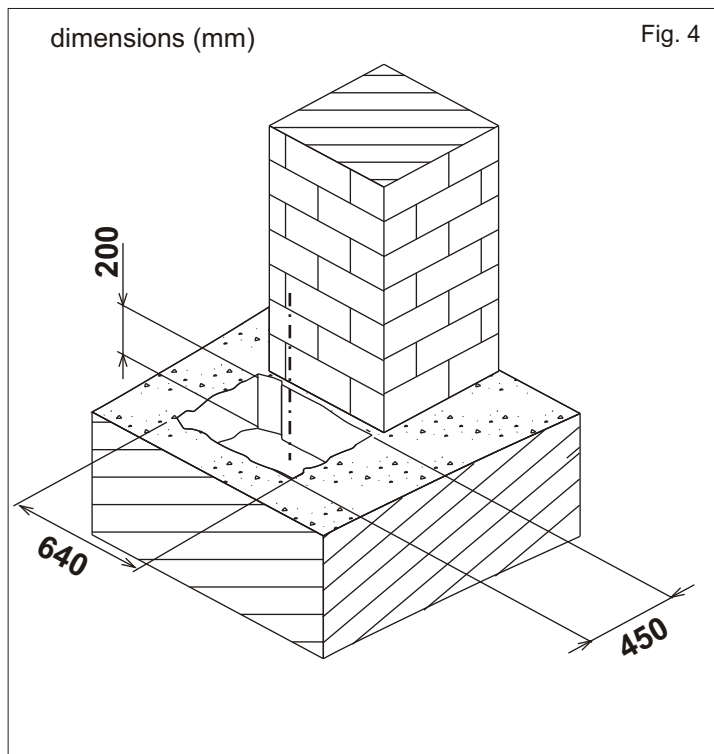

Fig. 4

2.2. Inside the excavated pit you have to plan:

**rain water drainage;**

a water waste pipe in PVC of about 40 mm of diameter to put inside the provided hole of the box before it is concreted (Fig. 5). **It must be brought until the drain of the sewer line;**

a sheath for the passage of electrical cables of about 20 mm of diameter which must be brought to the proximity of the electric connection box (Fig. 5).

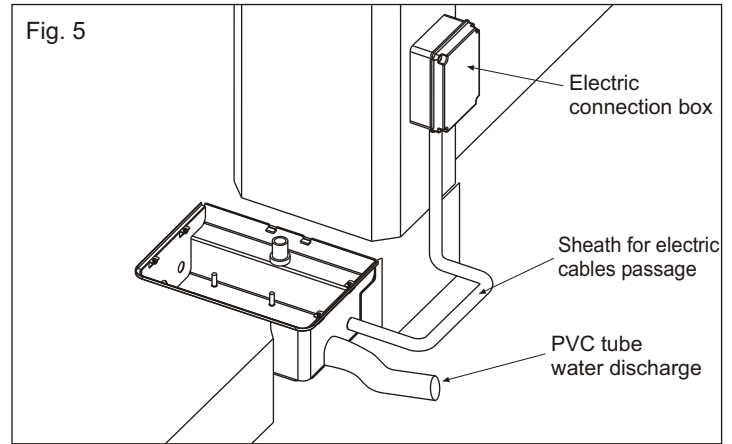

Fig. 5

2.3. Before concreting the carrying box, use a level to make it perfectly horizontal to the ground (Fig. 6) and perpendicular to the axis of the gate (Fig. 7).

The axis of the upper hinge of the gate must correspond exactly to the axis of the carrying box shaft.

Follow the distance of 64 mm closely between the carrying box cover and the base of the gate.

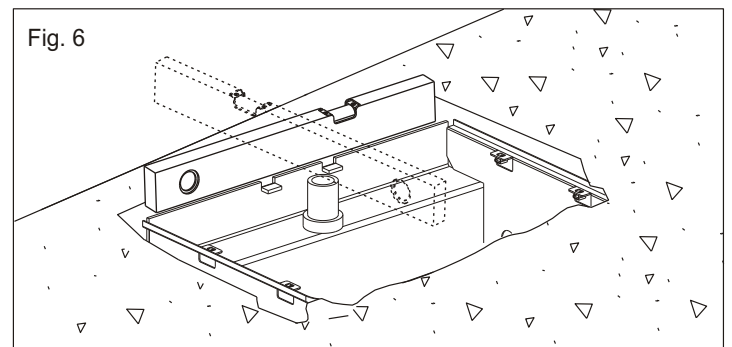

Fig. 6

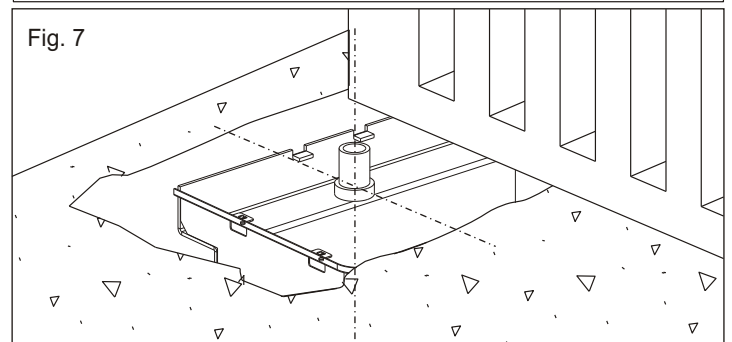

Fig. 7

2.4. Insert the ball into the perforated shaft (Fig. 8)

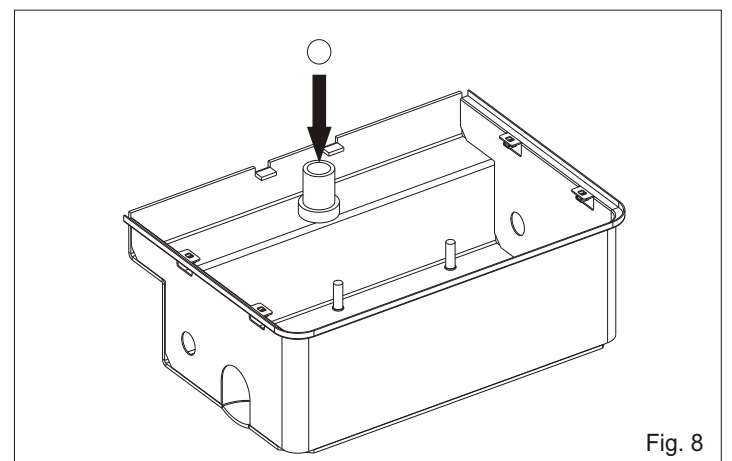

Fig. 8



2.5. Insert the handle bar device into the perforated shaft (Fig. 9)

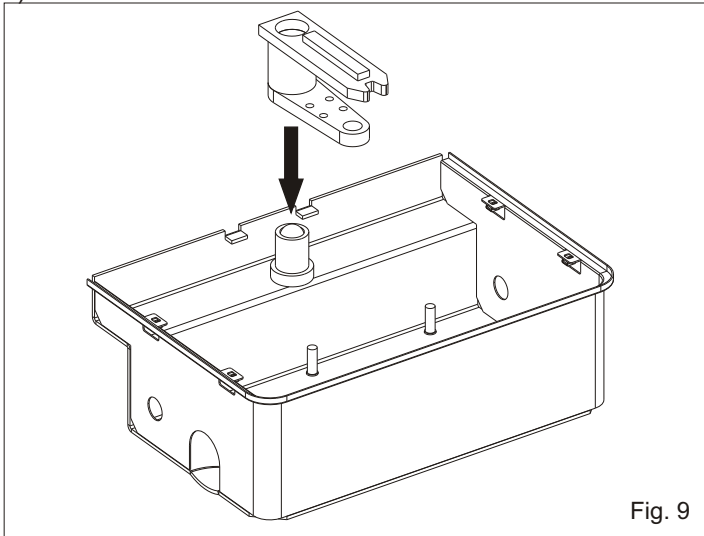

Fig. 9

2.6. Grease plentifully the hole A and insert the leaf device (Fig. 10)

**Grease the whole with the special greaser until the grease comes out of both sides. ▲**

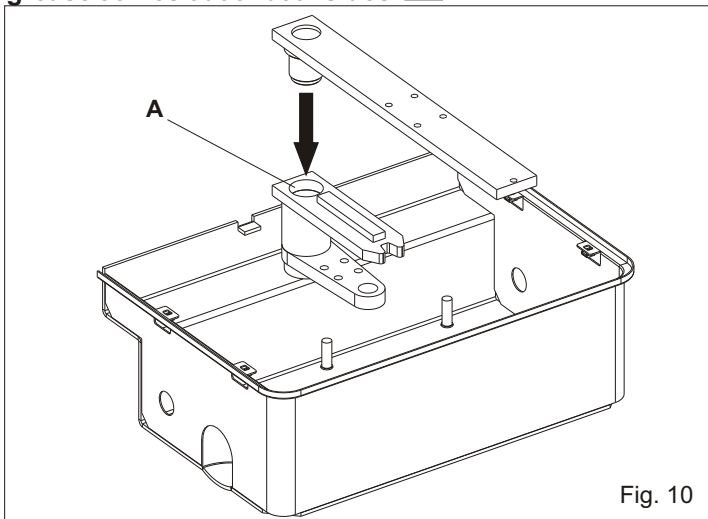

Fig. 10

2.7. Insert the cam of the limit switch into the handle bar and fix it with the special screws (left-hand side mounting Fig. 11, right-hand side mounting Fig. 12)

**N.B.: During the insertion of the units lubricate them with the supplied grease (Fig.8, Fig.9, Fig.10).**

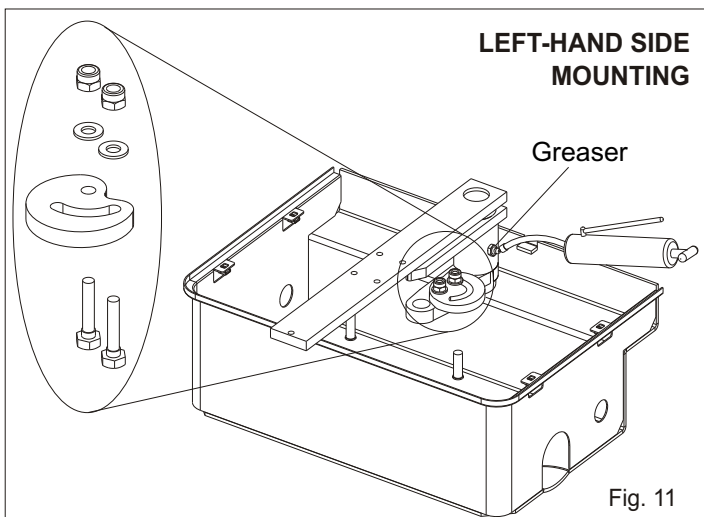

Fig. 11

**RIGHT-HAND SIDE MOUNTING**

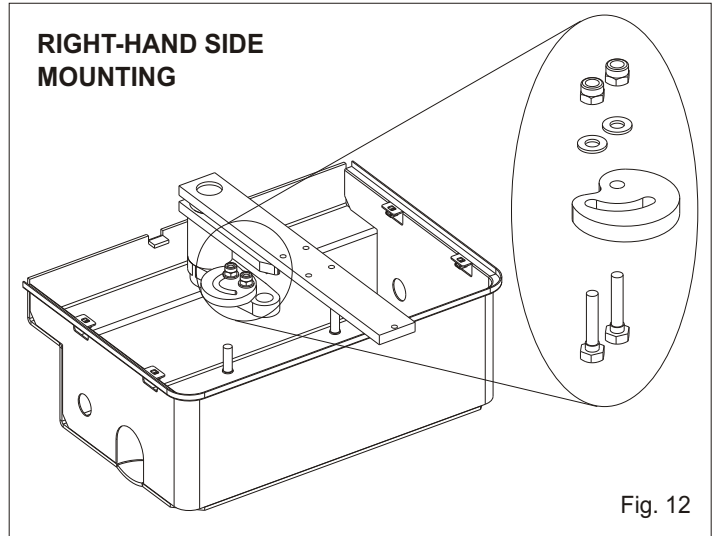

Fig. 12

**3. LEAF ASSEMBLING**

**Before installing the gate make sure that the concrete has hardened into the foundation hole.**

3.1. Position the leaf of the gate on the leaf device making reference to the rotation axe of the leaf hinge (Fig. 13);

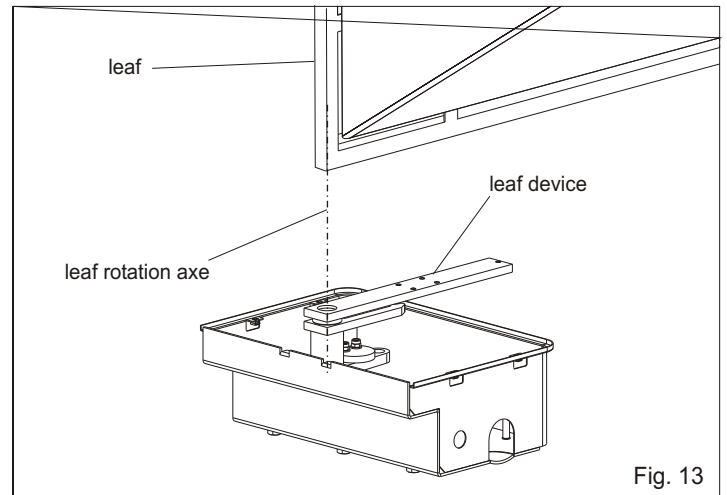

Fig. 13

3.2. Weld with care the leaf device to the leaf of the gate realizing a tract fixation of ca. 3-4 cm along the surface of the contact, avoiding the welding next to the threaded holes, furthermore it is necessary to respect the perpendicularity to the axe of rotation (Fig. 14)

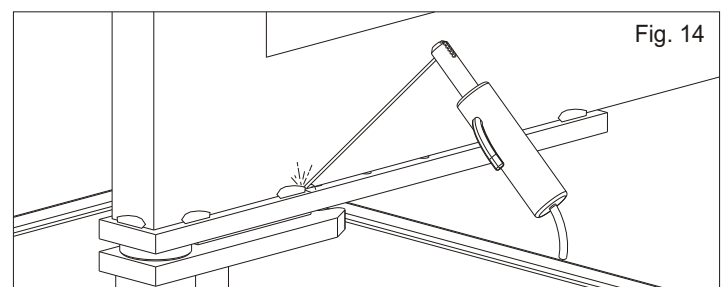
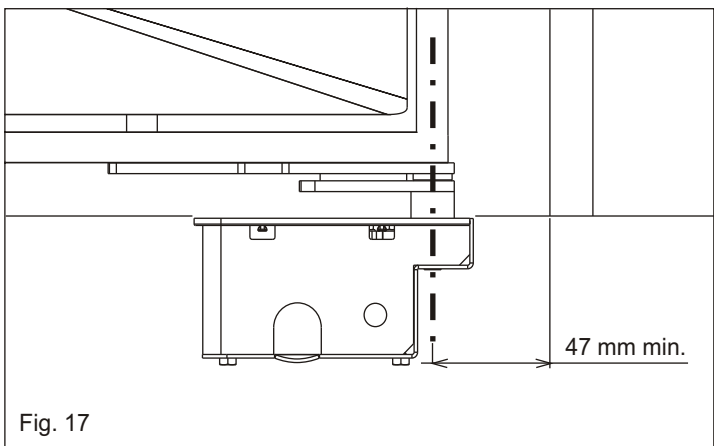
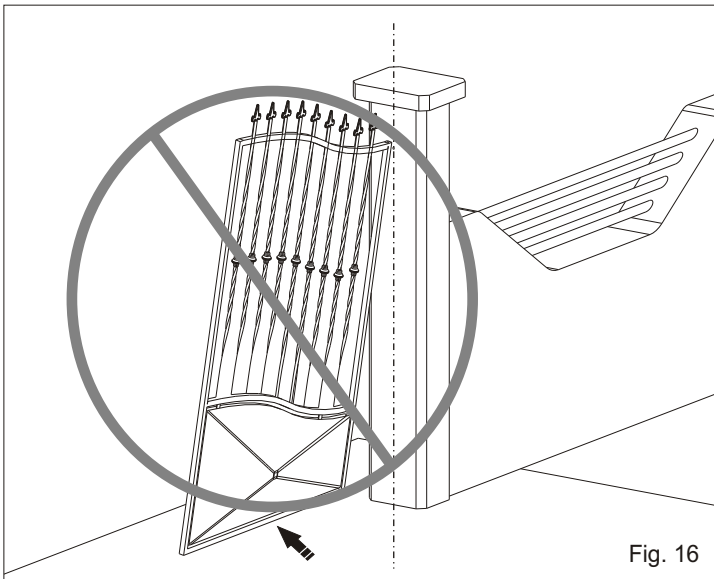
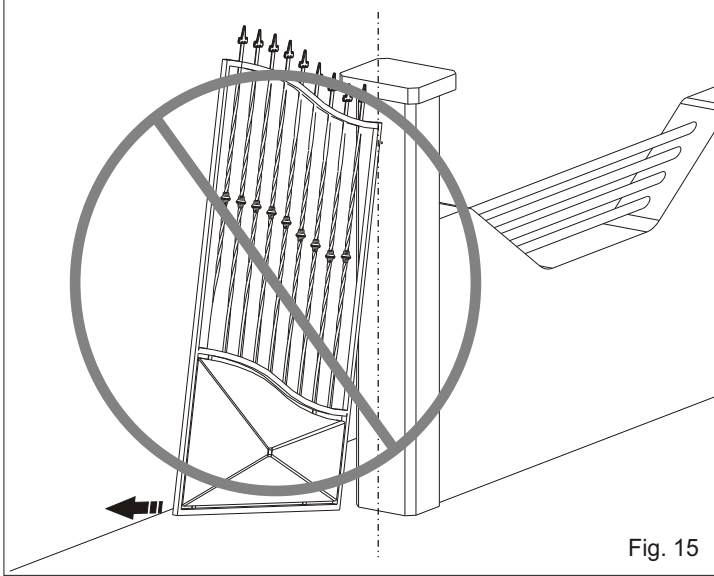

Fig. 14



3.3. Be careful not to place the leaf outside the axis (Fig. 15 and 16), but make sure the shaft corresponds to the hinge rotation axis remembering that the minimum distance from the pillar is 47 mm (Fig. 17).



## 4. INSTALLATION OF THE OPERATOR

4.1. It is important to distinguish the right hand and the left hand side operator, anyway the motor must always be turned against the opening side. Make reference to Fig. 18.

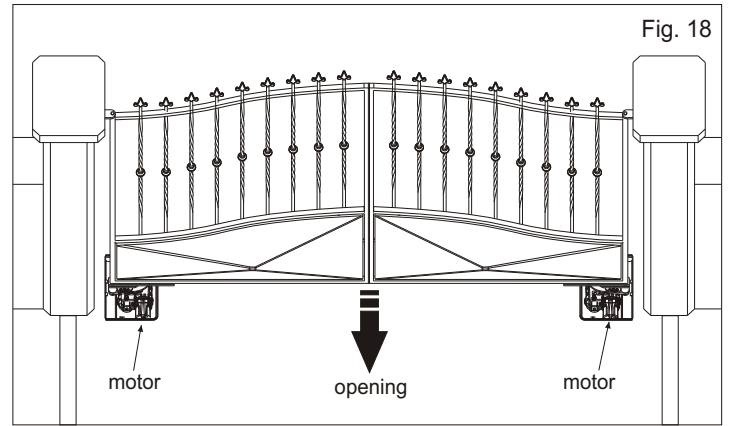

4.2. Introduce manually the operator into the inside of the carrying box (Fig. 19-20) and fix the operator with the 4 screws of the box using the furnished washers and nuts.

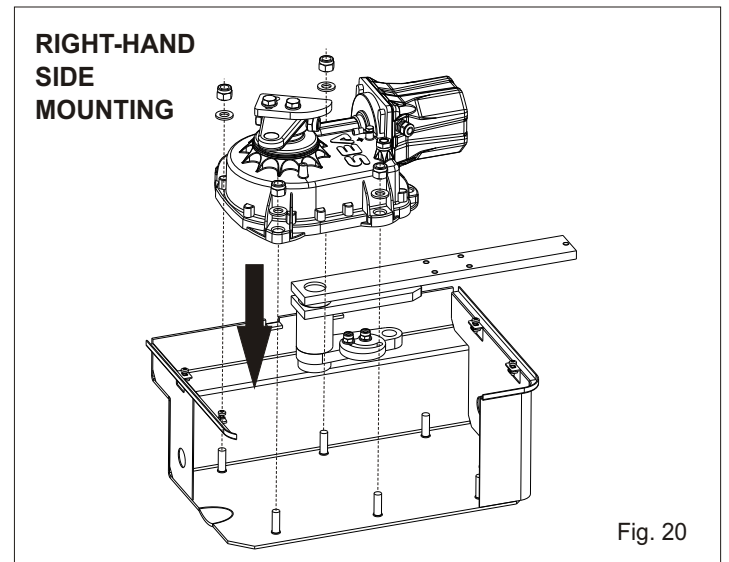
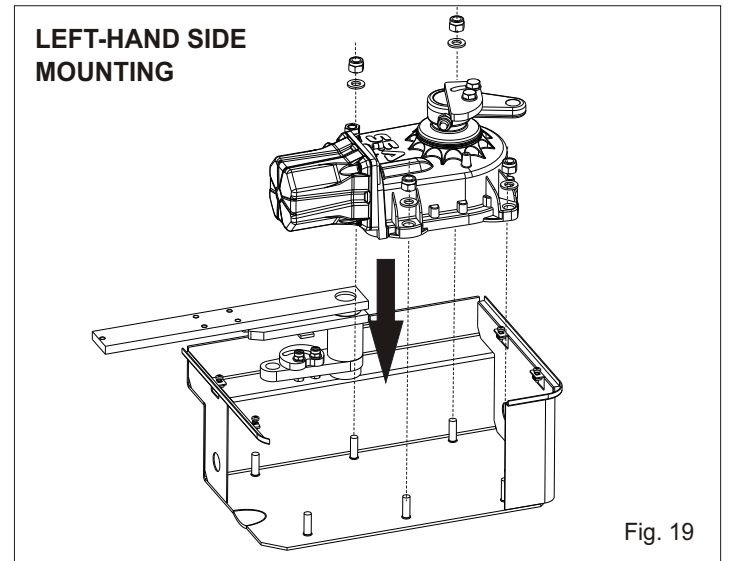



4.3. Connect the handle bar device to the motor using the counter-connecting rod through the special holes.

Note: Grease very well the holes and respect the direction of insertion of the counter-connecting rod (Fig. 21).

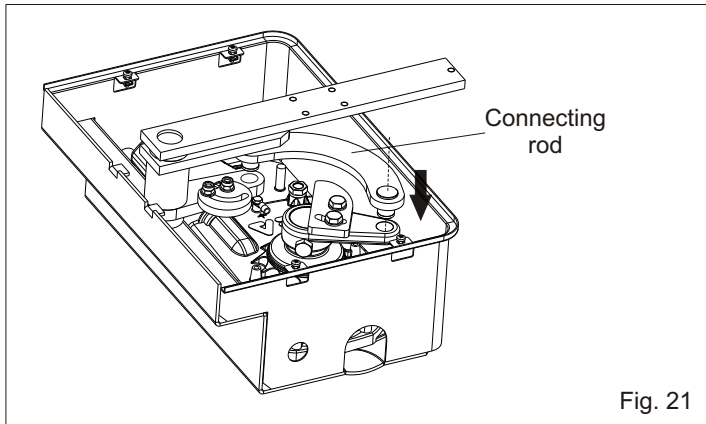

Fig. 21

## 5. MOUNTING OF THE RELEASE

For the Field there are foreseen two types of release: **RELEASE** (with personalised key) and **RELEASE PLUS** (with DIN key).

### RELEASE

5.1. Grease the hinge (A) and mount the release system under the leaf device using the 4 furnished screws (Fig. 22)

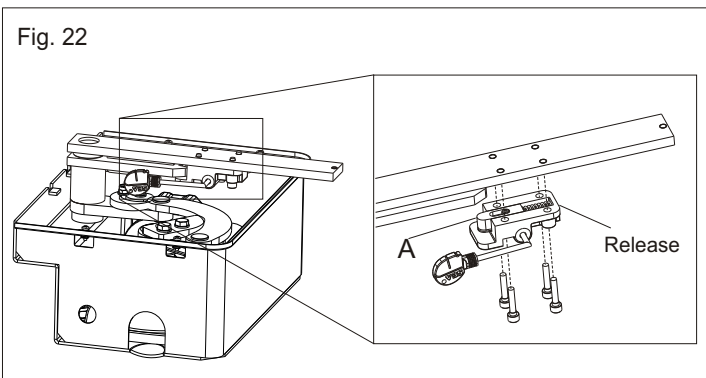

Fig. 22

### RELEASE PLUS

5.2. Grease the hinge (A) and mount the release system under the leaf device using the 5 furnished screws (Fig. 23)

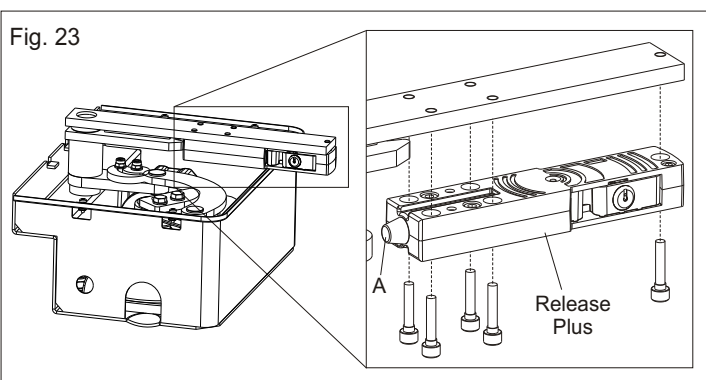

Fig. 23

Carry out the electrical connections to the control unit as described in the instructions supplied with SEA control unit.

## 6. LIMIT SWITCH ADJUSTMENT

For the limit switch adjustment in closing and in opening execute the following operations:

### Limit switch in closing

Even if in closing there are limit switch stops mounted on the ground it is necessary to adjust the limit switch of the Field, operate as follows:

6.1. Close the leaves completely

6.2. Mount the cam of the limit switch as shown in Fig. 24, bring it to the stop with the connecting rod and fix it with the special screws.

The mounting of the cam and its adjustment is shown in Fig. 25 and 26.

6.3. Adjustable limit switches in closing ( from 85° to 95° degrees)

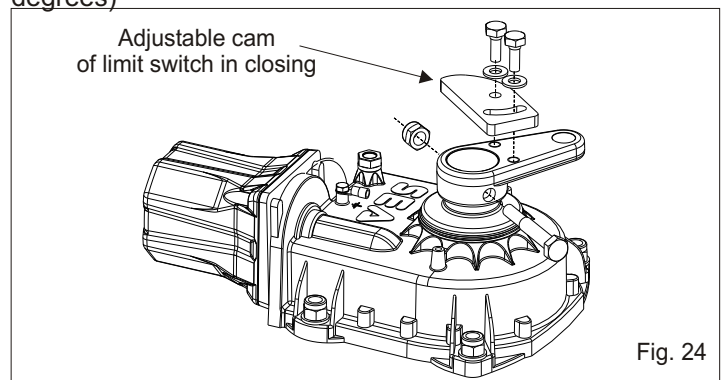

Fig. 24

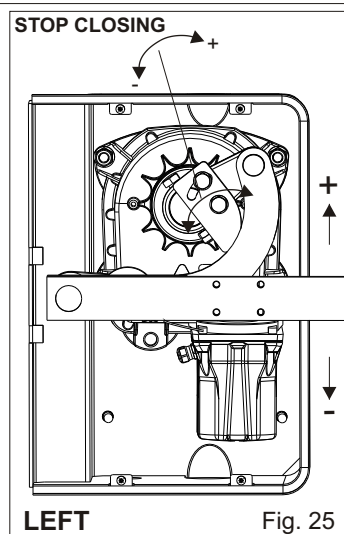

Fig. 25

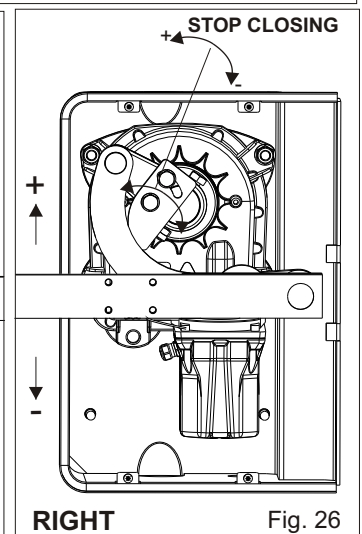

Fig. 26

### Limit switch in opening

It is recommended to have limit switch stops on the ground in opening, if already installed, it is not necessary to adjust the limit switches present on the Field.

If there are no limit switch stops in opening on the ground, operate as follows:

6.3. Open the leaves completely (1) and bring them back of about 10° (2) (Fig. 27).

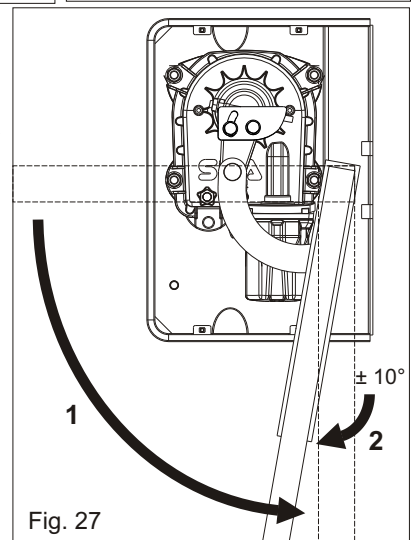
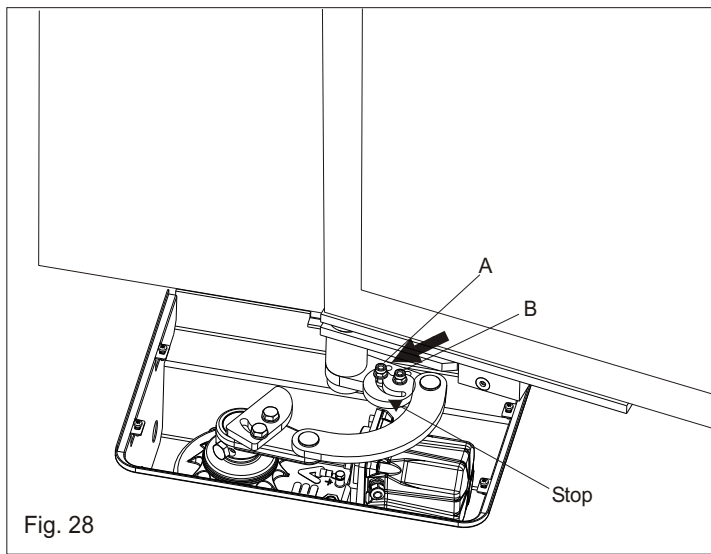

Fig. 27



**6.4.** Unscrew the nuts A and B, turn the cam with the counter-connecting rod until it reaches the stop and relock the nuts (Fig. 28)



In case of a not perfect positioning of the leaves in opening, it is possible to adjust the position through the cam.

Close the operator with the cover using the 4 enclosed screw.

After ending all the operations in the installation of the above mentioned carrying box, of the gate and the operator, try to do some moves slowly by hand verifying that there are not irregular frictions and that the movement is uniform for the whole range.

**Notice:** to do this last operation, release the operator as described in the next paragraph.

**When putting in function the installation it is peremptory to lubricate the box as in Fig. 11 until the grease comes out. (Use grease type DIN 51502 KP 2 N-20 - K 2 K-20).**

## 7. RELEASE SYSTEM

### RELEASE

**7.1. To release act as follows:**

- Insert the enclosed key into the keyhole (S) and turn the handle about 180° against the centre of the gate (Fig. 29).
- Keep the key locked and move the leaf, now turn back the key to the normal position and extract it.

**7.2. To stop again act as follows:**

- Move the leaf until the lock has coupled again.

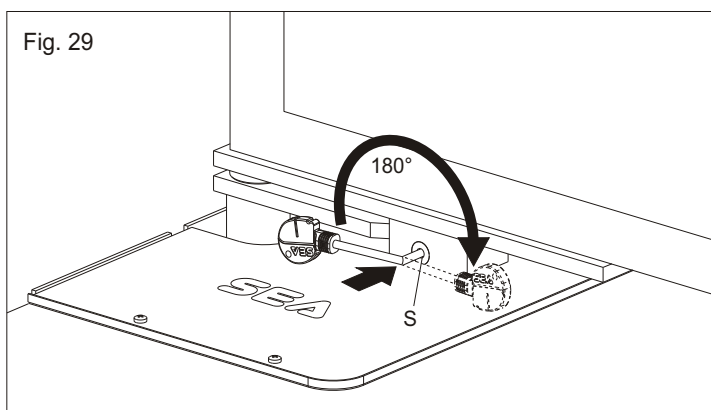

### RELEASE PLUS

**7.3. To release act as follows:**

- Insert the enclosed key into the keyhole and turn it about 90° in clockwise direction (Fig. 30).
- Pull the key against the external of the release making come out the handle of the lock until it reaches the stop (Fig.31).
- Move the leaf and make return the handle of the release in its original position and extract the key.

**7.4. To stop again act as follows:**

- Move the leaf until the lock has coupled again.

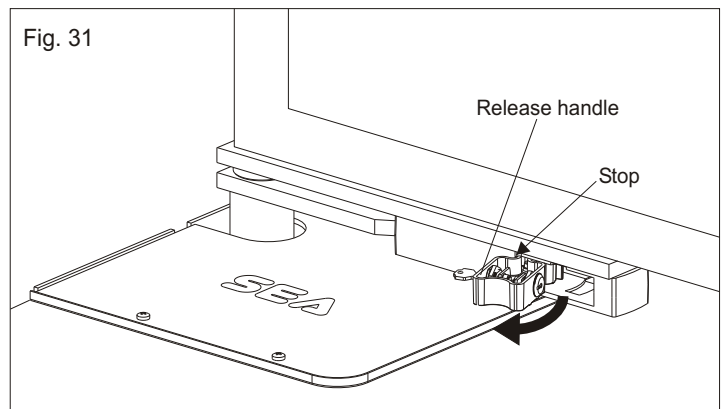
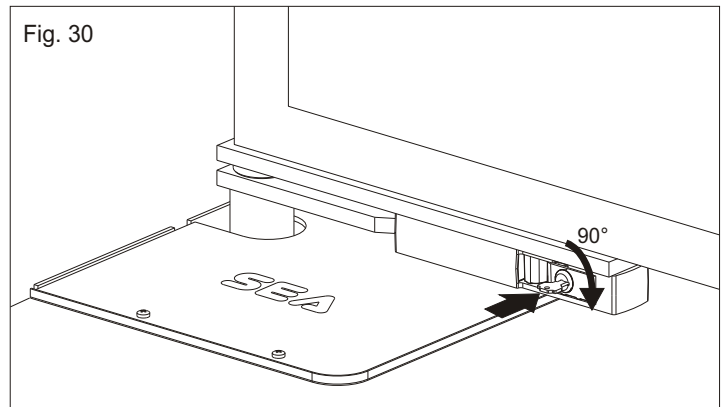

## 8. CABLE LAYOUT (Fig. 32)

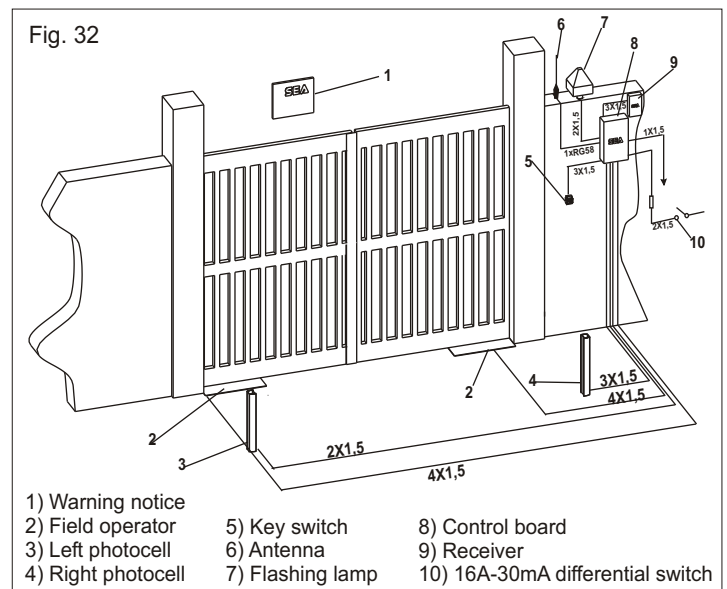



## 9. RISK EXAMINATION

The points pointed by arrows in Fig. 33 are potentially dangerous.

The installer must take a thorough risk examination to prevent crushing, conveying, cutting, grappling, trapping so as to guarantee a safe installation for people, things and animals (Re. Laws in force in the country where installation has been made.).

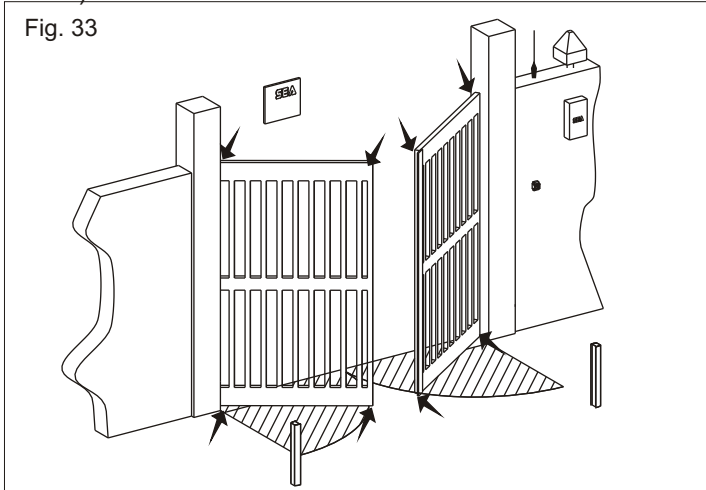

## PERIODICAL MAINTENANCE

Grease the parts in movement (counter-connecting rod, release, etc.)	Annual
Check the release function	Annual
Check if the screws are locked tight	Annual
Check the conditions of wear and tear of the devices in movement	Annual
Check the correct drain of the rainwater	Annual
Check the integrity of the connection cables	Annual

All the above described operations **must be made exclusively by an authorized installer.**

## NOTICE

As for misunderstandings that may arise refer to your area distributor or call our help desk. These instructions are part of the device and must be kept in a well known place. The installer shall follow the provided instructions thoroughly. SEA products must only be used to automate doors, gates and wings. Any initiative taken without SEA Srl explicit authorization will preserve the manufacturer from whatsoever responsibility. The installer shall provide warning notices on not assessable further risks. SEA s.r.l. in its relentless aim to improve the products, is allowed to make whatsoever adjustment without giving notice. This doesn't oblige Sea to up-grade the past production. SEA s.r.l can not be deemed responsible for any damage or accident caused by product breaking, being damages or accidents due to a failure to comply with the instructions herein. The guarantee will be void and the manufacturer responsibility (according to Machine Law) will be nullified if SEA Srl original spare parts are not being used.

The electrical installation shall be carried out by a professional technician who will release documentation as requested by the laws in force. This is a quotation from the GENERAL DIRECTIONS that the installer must read carefully before installing. Packaging materials such as plastic bags, foam polystyrene, nails etc must be kept out of children's reach as dangers may arise.

To respect the norms in force it is recommended to use the SAFETY GATE system together with the electronic control unit GATE.

## DECLARATION OF CONFORMITY

SEA declares under its responsibility that the products

*Field, Field Fast, Field 24V and Filed 250*

meet the essential requisites provided for by the following European Directive and following changes:

**89/392/CEE (Machine Directive)**

**89/336/CEE (Electromagnetic Compatibility Directive)**

**73/23/CEE (Low Tension Directive)**

## SAFETY PRECAUTIONS:

All electrical work should conform to current regulations. A 16 A 0,030 A differential switch must be incorporated into the source of the operators main electrical supply and the entire system properly earth bonded. Always run mains carrying cables in separate ducts to low voltage control cables to prevent mains interference.

## INTENDED USE:

Field undergrounded operators have been designed to be used only for the automation of swing gates.

## SPARE PARTS:

To obtain spare parts contact:

**SEA s.r.l. -Zona Ind.le, 64020 S. ATTO Teramo Italia**

## SAFETY AND ENVIRONMENTAL COMPATIBILITY:

Don't waste product packing materials and/or circuits.

When being transported this product must be properly packaged and handled with care.

## MAINTENANCE AND OUT OF SERVICE:

The decommission and maintenance of this unit must only be carried out by specialised and authorised personnel.

**NOTE: THE MANUFACTURER CAN NOT BE DEEMED RESPONSIBLE FOR ANY DAMAGE OR INJURY CAUSED BY IMPROPER USE OF THIS PRODUCT.**

*SEA reserves the right to do changes or variations that may be necessary to its products with no obligation to notice.*