

FITTING AND CONNECTION INSTRUCTIONS

ENGLISH

The Compact 400/800 consists of a hydraulic pump and a hydraulic jack, both of which coupled in a **supporting box treated with cathoporesis**.

The pump unit casing, which is used as an oil tank, contains the electric motor, fluid pump, distributor and hydraulic oil.

It is also provided with an **adjustable slowing-down device** in the two stop phases of the leaf (versions with slow-down only).

The wheeling unit is composed by a double piston connected to a rack which engages with the pinion of the leaf dragging shaft.

Gates up to 2 meters long can be securely locked using the operators internal hydraulic locking system, thus ensuring perfect keeping in closing and in opening.

For gate in excess of stated value: A hydraulic non locking operator should be used in conjunction with a separate electrical locking device to ensure keeping in closing.

For rotation angles not included between 90°-100 and 130°-140° respectively, slowing down is either in closing or in opening.

In case of power failure: The operator's internal hydraulic locking can be released using a special key and the gate used manually.

MAIN PARTS NOMENCLATURE

- | | |
|---|--------------------------------------|
| 1 Release Cover | 6 Filling oil Cap |
| 2 Release Extention | 7 Oil level indicator |
| 3 Braking regulation screw (where provided) | 8 Water draining hole |
| 4 Exit hole for electric cables | 9 Draining screw |
| 5 By-pass regulation | 10 Screw for braking regulation stop |
| | 11 Greaser |

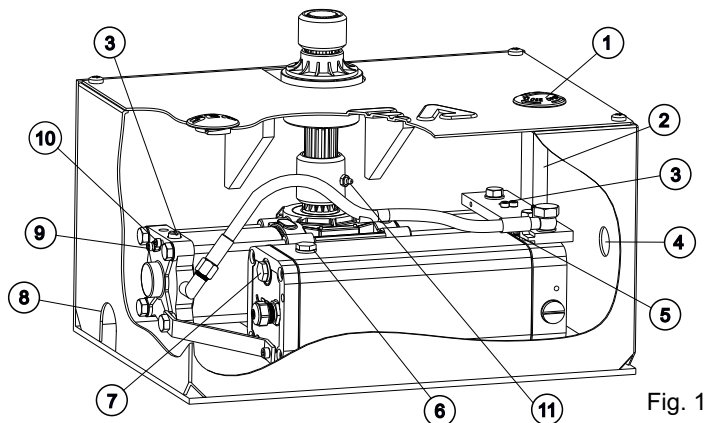
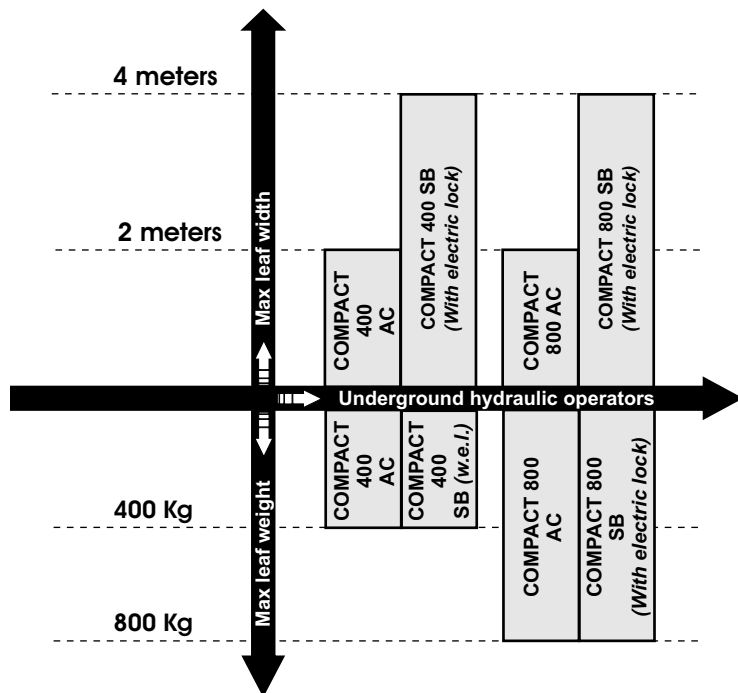

Fig. 1

| TECHNICAL DATA | Compact 400 | Compact 800 |
|---|---------------------------------|-------------|
| Power supply | 230 V (±5%) 50/60 Hz | |
| Motor Power | 220 W | |
| Absorbed current | 1,1 A | |
| Motor rotation speed | 1400 rpm | |
| Cycles hour (with a 20°C temperature) | 45 | |
| Max Pressure of the 0,50 lt pump in use | 50 bar | |
| Max Pressure of the 0,75 lt pump in use | 40 bar | |
| Operating temperature | -20°C +55°C | |
| Thermal protection intervention | 130°C | |
| Max torque | 56 da Nm | |
| Starting capacitor | 12,5uF | |
| Weight | 13 Kg | 13,8 Kg |
| Protection class | IP55 | |
| Maximum weight of the gate | 400 Kg | 800 Kg |
| Braking regulation | On control unit or on operator* | |

* In case of operator with hydraulic slow down

GRAPHIC FOR THE USE OF COMPACT 400 AND COMPACT 800 OPERATORS



DIMENSIONS (mm)

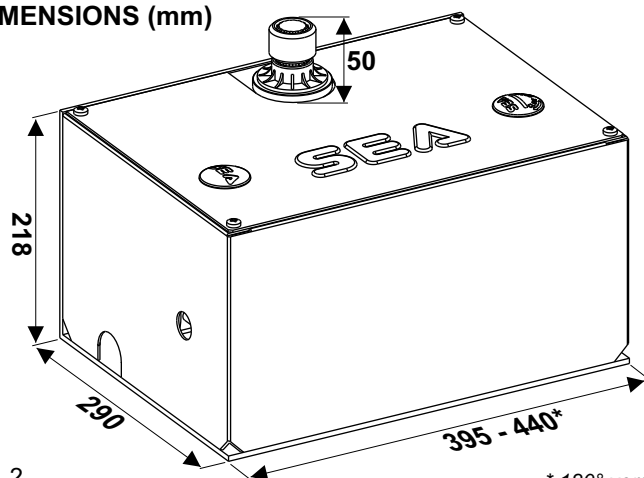

Fig. 2

* 180° version

1. GATE ARRANGEMENT

You must do some checks on the gate to see if fitting a COMPACT system is possible:

- A.** (Make sure that) the fixed and moving parts of the gate are strong and non-deformable;
- B.** the weight of each gate leaf must not exceed 400 Kg (**Compact 400**), 800 Kg (**Compact 800**);
- C.** the hinges and general structure must be in good condition and the gate must move smoothly throughout its travel;
- D.** the upper hinge alone is sufficient to install the unit; those which are unnecessary can be eliminated (the lower and that in the middle if exists);
- E.** as the limit switches are not provided within the actuator, it is necessary to install mechanical limit switches stops to be fixed to the ground in closing and in opening (Fig. 3).

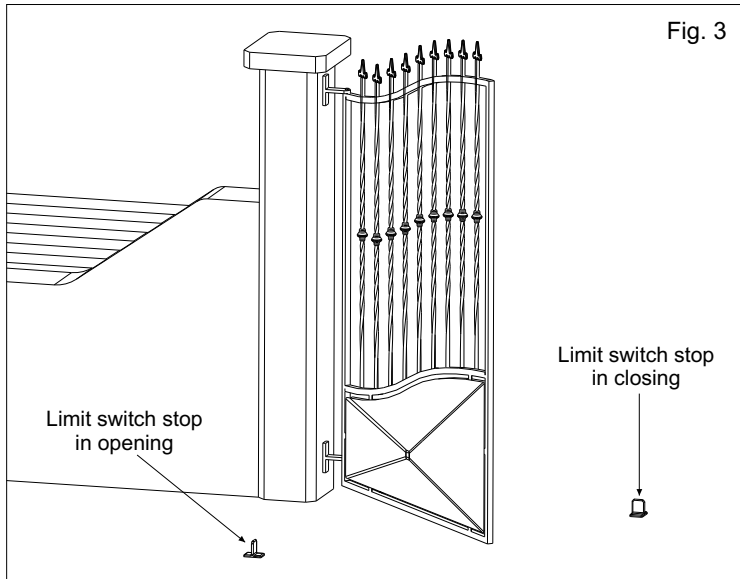

Fig. 3

2. CARRYING BOX INSTALLATION

2.1. The hole which contains the carrying box must have the approximate dimensions mentioned in Fig. 4.

For a correct placing, it is obligatory to follow closely the quote of 60 mm which corresponds to the minimum distance of the rotation axis from the pillar.

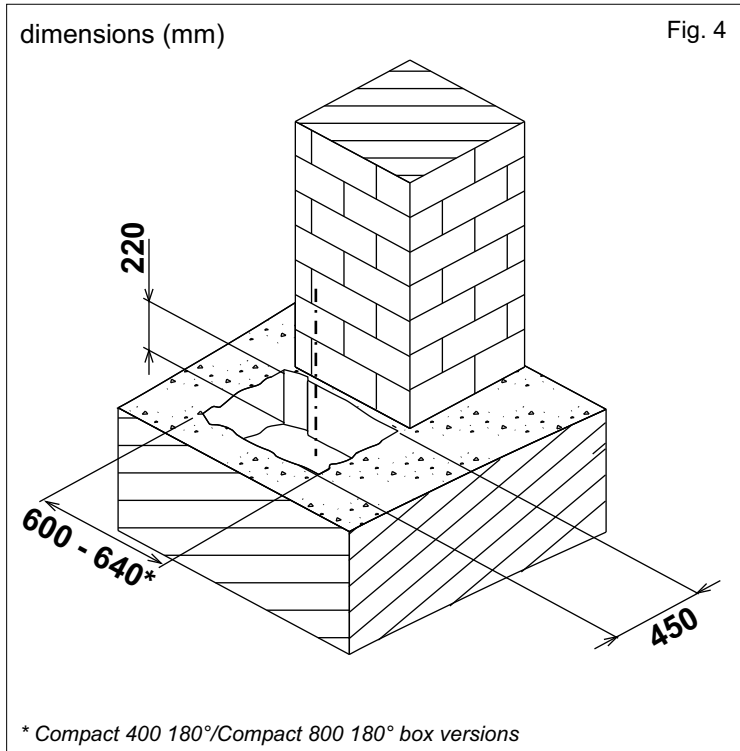

Fig. 4

* Compact 400 180°/Compact 800 180° box versions

2.2. Inside the excavated pit you have to plan:

rain water drainage;

a water waste pipe in flexible plastic of about 40 mm of diameter to put inside the provided hole of the box before it is concreted (Fig. 5). **It must be brought until the drain of the sewer line;**

a sheath for the passage of electrical cables of about 20 mm of diameter which must be brought to the proximity of the electric connection box (Fig. 5).

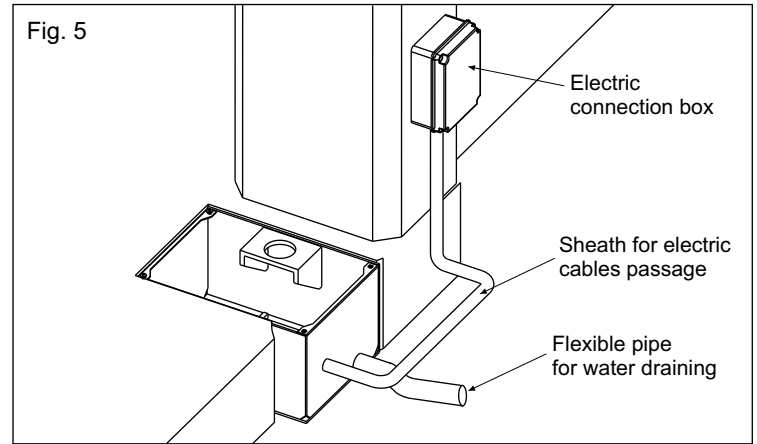

Fig. 5

2.3. Before concreting the carrying box, use a level to make it perfectly horizontal to the ground (Fig. 6) and perpendicular to the axis of the gate (Fig. 7).

The axis of the upper hinge of the gate must correspond exactly to the axis of the carrying box shaft.

Follow the distance of 50 mm closely between the carrying box cover and the base of the gate (Fig. 2) remembering that the U-shaped iron will be inserted on it (see the paragraph 3).

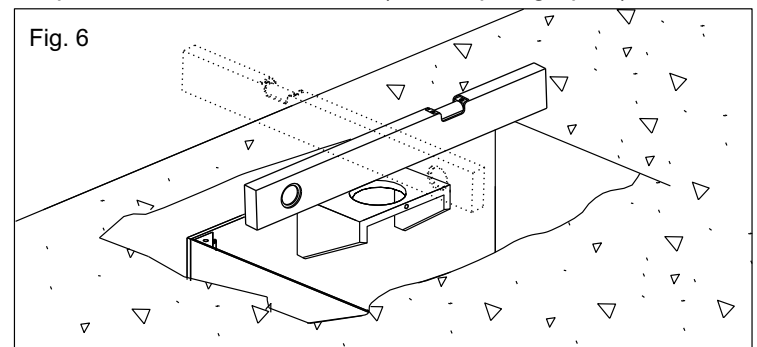

Fig. 6

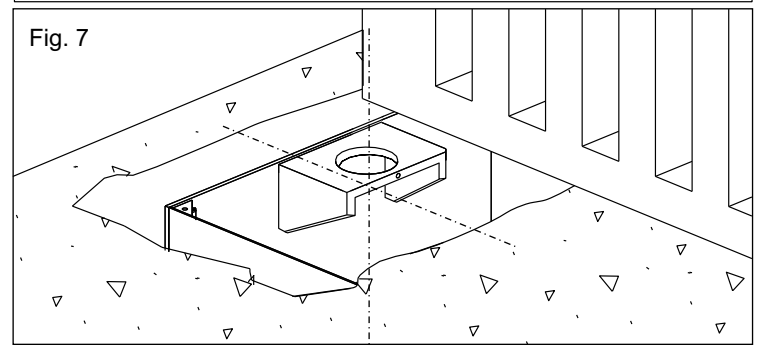

Fig. 7

2.4. Put the jointed splined shaft into the upper hole of the carrying box and fix it with the provided screw (Fig. 8)

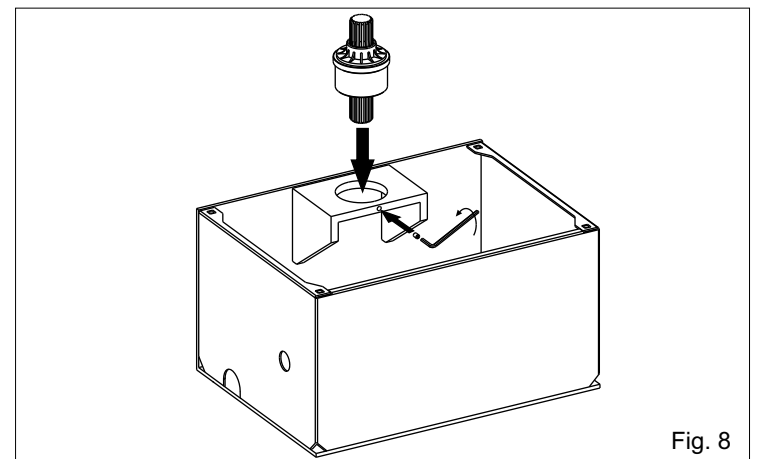

Fig. 8



3. LEAF ASSEMBLING

Before installing the gate make sure that the concrete has hardened into the foundation hole.

3.1. Assemble the gate shoe which consists of a U-shaped iron piece with a length of about 250 mm, which has an inside part like the thickness of the leaf.

3.2. Place the bush on the U-shaped iron referring to the rotation axis of the leaf hinge (Fig. 9);

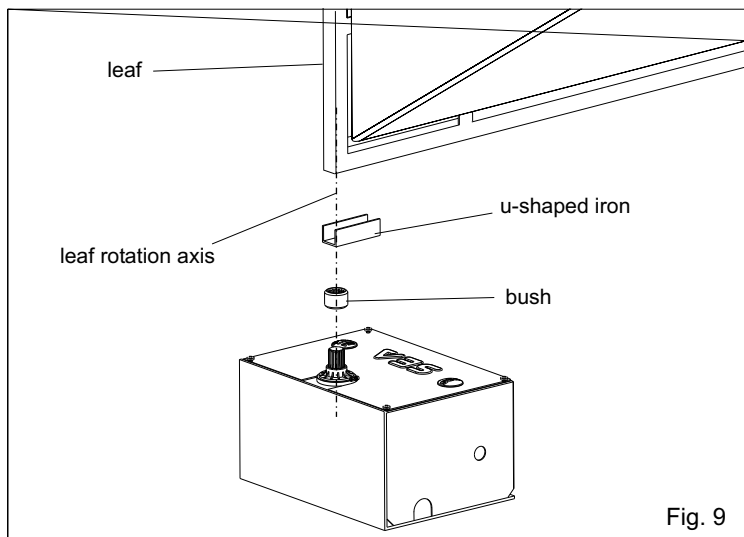

Fig. 9

3.3. solder the bush carefully to the iron to closely follow the perpendicularity with the rotation axis (Fig. 10)
NOTICE: The soldering waste must not fall on the operator, try to protect it or solder away from it.

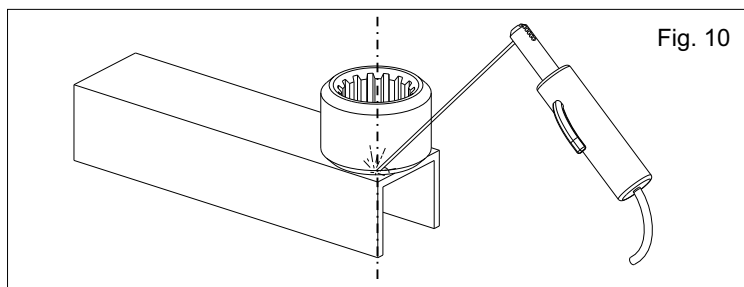

Fig. 10

3.4. close off one end of the U-shaped by welding from the post/pier side a suitable piece of plate.

3.5. Liberally grease the splined pinion on the box.

3.6. Put the U-shaped iron into the shaft of the carrying box.

3.7. Place the gate leaves on the U-shaped iron (Fig. 11) and connect them to the hinges in the upper part.

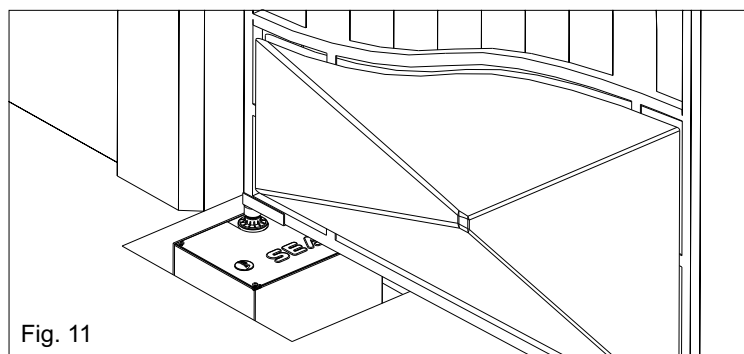

Fig. 11

It is important not to weld the gate leaf directly to the shoe.

3.8. Be careful not to place the leaf outside the axis (Fig. 12 and 13), but make sure the shaft corresponds to the hinge rotation axis remembering that the minimum distance from the pillar is 60 mm (Fig. 14).

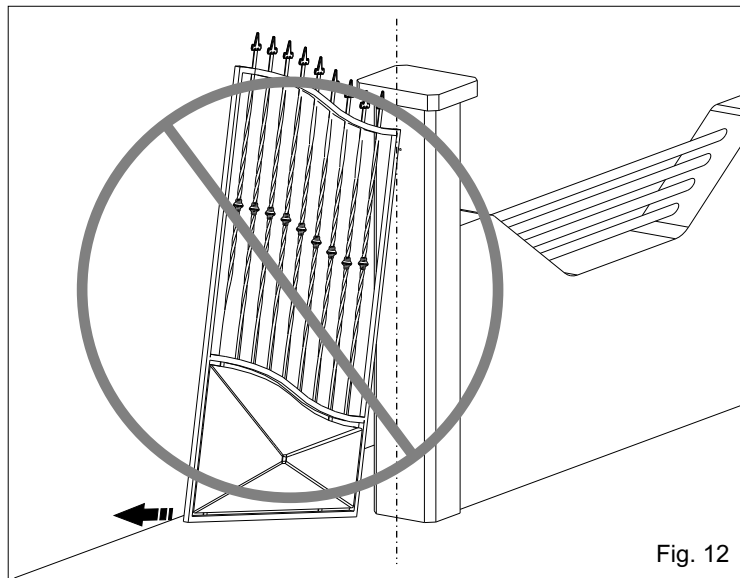

Fig. 12

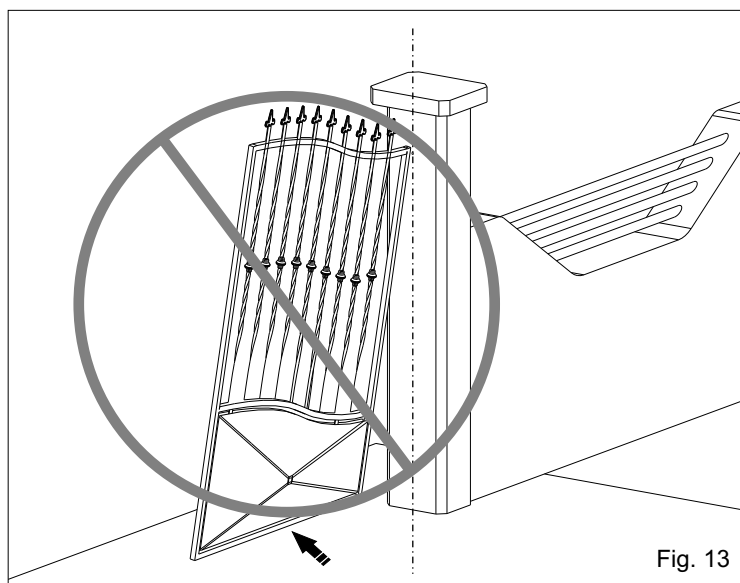

Fig. 13

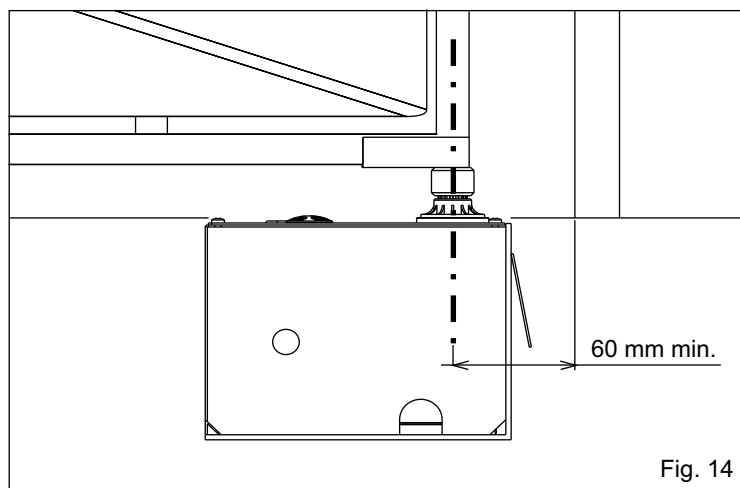

Fig. 14



4. INSTALLATION OF THE OPERATOR

4.1. Before putting the operator into the carrying box, install the release extension (Fig. 15).

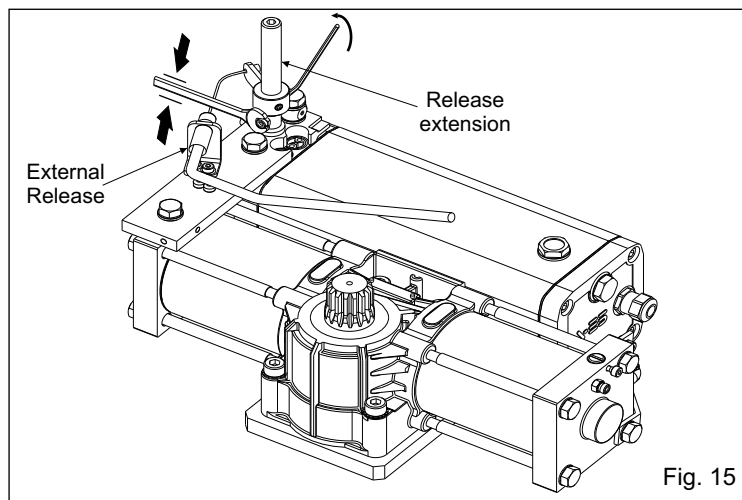

Fig. 15

4.2. It is important to identify the right operator and the left operator, in any case the release system must be always placed inside the place of residence. Make reference to Fig. 16.

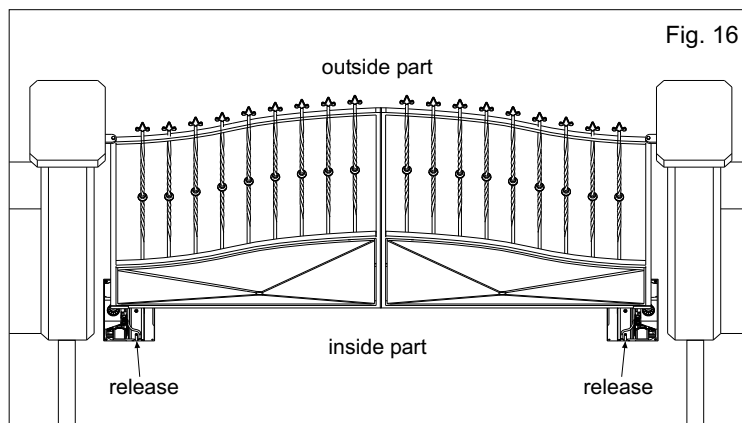

Fig. 16

4.3. Put the operator inside the carrying box by hand (Fig. 17) and couple the pinion of the operator with the pinion of the box using the jointed splined bush (Fig. 18).

Grease the splined joint with the special greaser until the grease comes out from both sides. ▲

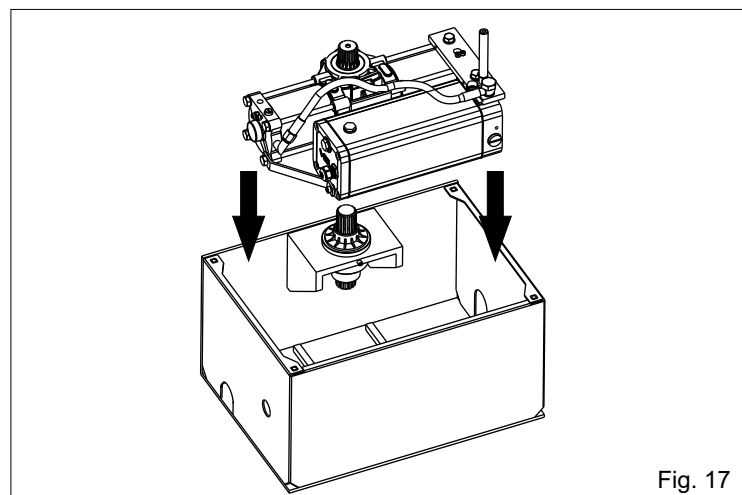

Fig. 17

4.4. Carry out the electrical connections to the control unit as described in the instructions supplied with SEA control unit.

After ending all the operations in the installation of the above mentioned carrying box, of the gate and the operator, try to do some moves slowly by hand verifying

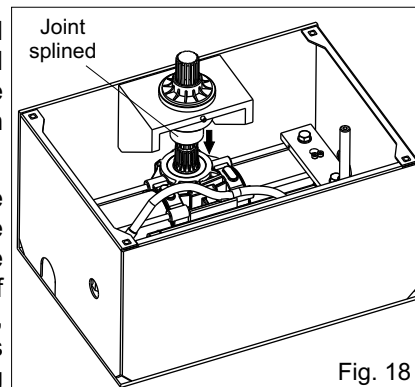

Fig. 18

That there are not irregular frictions and that the movement is uniform for the whole range.

Notice: to do this last operation, release the operator as described in the next paragraph.

5. RELEASE SYSTEM

5.1. To release act as follows:

- Use the supplied key top surface to open the release cap which protects the extension previously installed (Fig. 19)
- Put the key into the release extension and turn the handle of about 180° anti-clockwise (Fig. 20)
- Take the key off and close the hole with the release cap.

5.2. To stop again act as follows:

- Use the supplied key top surface to open the release cap
- Put the key into the release extension and turn the handle clockwise until it stops.
- Take the key off and close the hole with the release cap.

5.3. External release:

- Being an emergency manoeuvre, the external release has the only function to release, **to relock the operator it is always necessary to use the internal release.** (Fig. 15) ▲

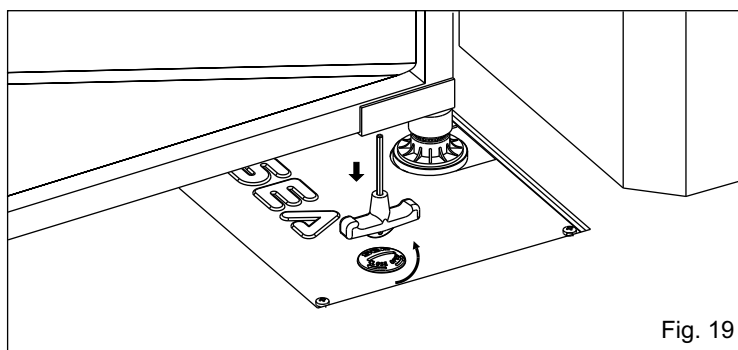

Fig. 19

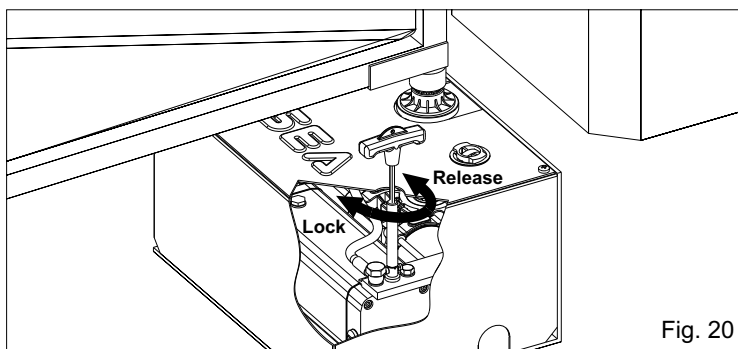

Fig. 20



6. REGULATION OF THE PUSHING FORCE

The pushing force or anti-crushing force must be valued by hand or better with a dynamometer and in both the ways of rotation.

To regulate such force act as follow:

act on the by-pass valves with the provided key, given to the authorised installers, clockwise to increase the force, anti-clockwise to decrease it (Fig. 21).

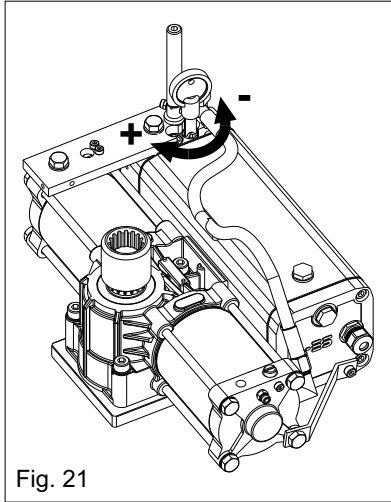

The adjustment is carried out with the gate moving and will not change the speed of the leaf.

Notice: The maximum regulation is of 15Kgf following the UNI EN 12453 law.

The motor run time is the last adjustment to make. It should be set 2 to 4 seconds higher than it takes to the gate to reach its stop. (this last regulation must be done on the electronic control unit).

Fig. 21

7. BRAKING REGULATION (where present)

7.1. It is possible to regulate the leaf slowdown in opening and in closing, through the braking adjusting screw (Fig. 22).

7.2. To regulate slowdown operate as follow:

- Loosen the blocking screw of braking regulation
- Act on the adjusting screw clockwise to have a higher braking and a speed decrease;
- Act on the adjusting screw anti-clockwise to have a lower braking and a speed increase;
- After the regulation fix the blocking screw of braking regulation.

For rotation angles not included between 90°-100 and 130°-140° respectively, slowing down is either in closing or in opening.

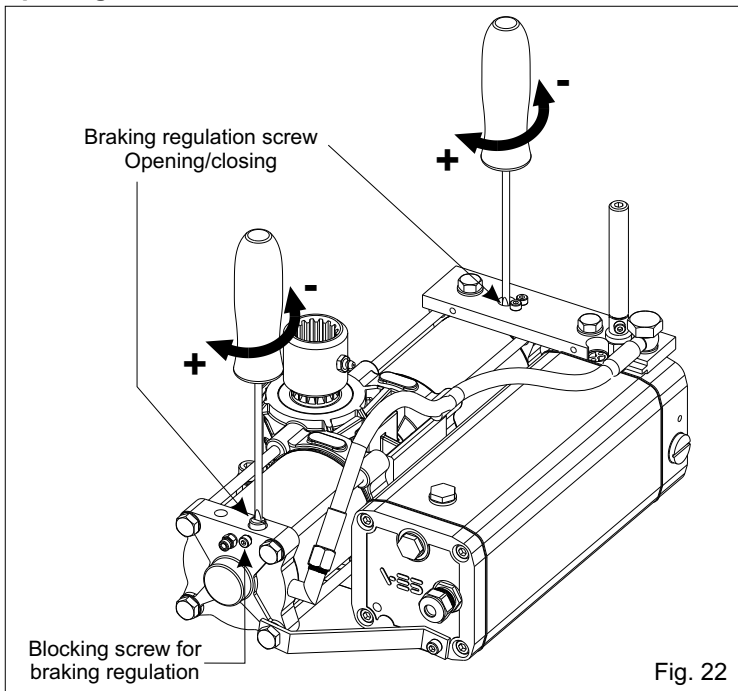
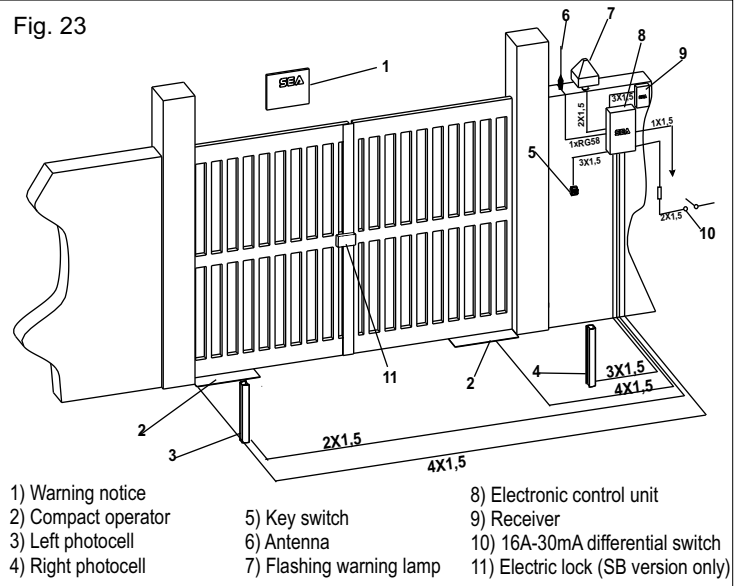

Fig. 22

8. CABLE LAYOUT (Fig. 23)

Fig. 23



- | | | |
|---------------------|-------------------------------------|----------------------------------|
| 1) Warning notice | 5) Key switch | 8) Electronic control unit |
| 2) Compact operator | 6) Antenna | 9) Receiver |
| 3) Left photocell | 7) Flashing warning lamp | 10) 16A-30mA differential switch |
| 4) Right photocell | 11) Electric lock (SB version only) | |

9. RISK EXAMINATION

The points pointed by arrows in Fig. 24 are potentially dangerous. The installer must take a thorough risk examination to prevent crushing, conveying, cutting, grappling, trapping so as to guarantee a safe installation for people, things and animals (Re. Laws in force in the country where installation has been made.).

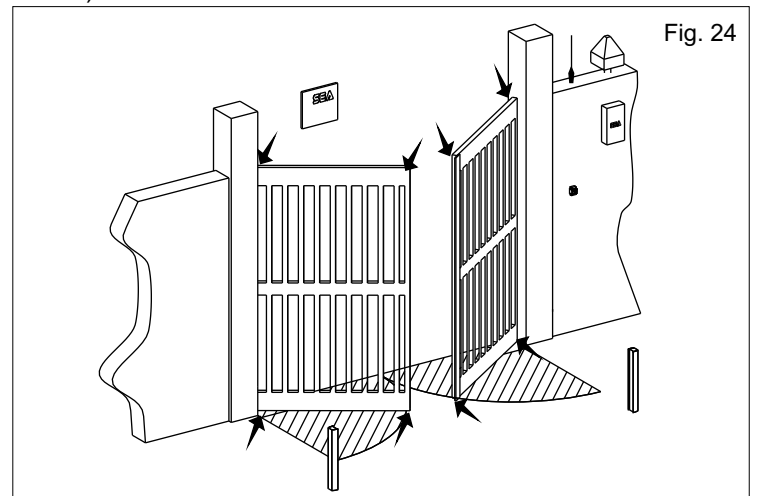

Fig. 24

NOTICE

As for misunderstandings that may arise refer to your area distributor or call our help desk. These instructions are part of the device and must be kept in a well known place. The installer shall follow the provided instructions thoroughly. SEA products must only be used to automate doors, gates and wings. Any initiative taken without SEA Srl explicit authorization will preserve the manufacturer from whatsoever responsibility. The installer shall provide warning notices on not assessable further risks. SEA s.r.l. in its relentless aim to improve the products, is allowed to make whatsoever adjustment without giving notice. This doesn't oblige Sea to up-grade the past production. SEA s.r.l can not be deemed responsible for any damage or accident caused by product breaking, being damages or accidents due to a failure to comply with the instructions herein. The guarantee will be void and the manufacturer responsibility (according to Machine Law) will be nullified if SEA Srl original spare parts are not being used.

The electrical installation shall be carried out by a professional technician who will release documentation as requested by the laws in force. This is a quotation from the GENERAL DIRECTIONS that the installer must read carefully before installing. Packaging materials such as plastic bags, foam polystyrene, nails etc must be kept out of children's reach as dangers may arise.



SAFETY GATE

For a correct and safe installation it is strongly recommended to install a Safety Gate, **which allows the fulfilment of the force diagram included in the norm EN 12453** and consequently the test and start of the whole installation.

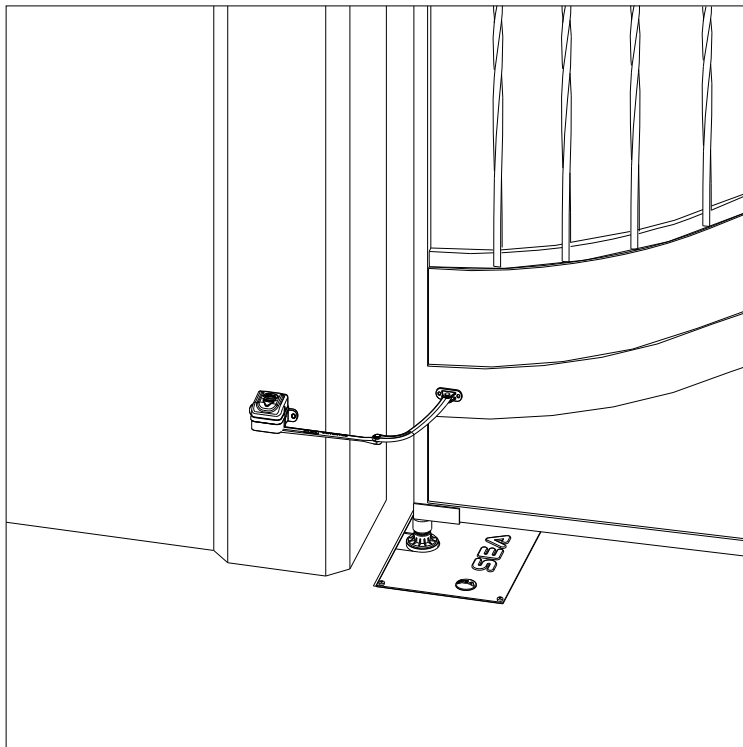

PERIODICAL MAINTENANCE

| | |
|--|---------|
| Check the oil level (Trasparent cap n.7 in Fig. 1) | Annual |
| Change the oil | 2 years |
| Verify the functionality of the by-pass valves (check the force in opening and closing) | Annual |
| Check the release function | Annual |
| Verify the slowdown regulation (where present) | Annual |
| Verify the wear condition of the splined shaft and of the splined bush | Annual |
| Check the correct drain of the rainwater | Annual |
| Check the integrity of the connection cables | Annual |
| Grease the splined joint | Annual |

All the above described operations must be made exclusively by an authorized installer.

DECLARATION OF CONFORMITY

SEA declares under its responsibility that the products

Compact 400, Compact 800

meet the essential requisites provided for by the following European Directive and following changes:

89/392/CEE (Machine Directive)

89/336/CEE (Electromagnetic Compatibility Directive)

73/23/CEE (Low Tension Directive)

SAFETY PRECAUTIONS:

All electrical work should conform to current regulations. A 16 A 0,030 A differential switch must be incorporated into the source of the operators main electrical supply and the entire system properly earth bonded. Always run mains carrying cables in separate ducts to low voltage control cables to prevent mains interference.

INTENDED USE:

Compact 400 and Compact 800 undergrounded operators have been designed to be used only for the automation of swing gates.

SPARE PARTS:

To obtain spare parts contact:

SEA s.r.l. -Zona Ind.le, 64020 S. ATTO Teramo Italia

SAFETY AND ENVIRONMENTAL COMPATIBILITY:

Don't waste product packing materials and/or circuits.

When being transported this product must be properly packaged and handled with care.

MAINTENANCE AND OUT OF SERVICE:

The decommission and maintenance of this unit must only be carried out by specialised and authorised personnel.

NOTE: THE MANUFACTURER CAN NOT BE DEEMED RESPONSIBLE FOR ANY DAMAGE OR INJURY CAUSED BY IMPROPER USE OF THIS PRODUCT.

SEA reserves the right to do changes or variations that may be necessary to its products with no obligation to notice.