

BULL BOLLARD

HYDRAULIC BOLLARD OPERATOR
FOR INDUSTRIAL USE. INTENSIVE
OPENING CYCLES.



Strong, reliable, safe, silent and secure!

- Robust self-contained hydraulic system, quiet in operation and offering long term durability.
- In-built hydraulic pump, piston, three stabilising support shafts and industrial sealed limits switches ensure consistent operation and ease of installation.
- 1150 mm plastic foundation sleeve and 550 mm checker plate manhole cover supplied as standard.
- Complete with LED illumination to indicate bollard movement and 10 metres of pre-wired cabling.
- Standard 6mm outer casing. Super Bull also available with a 12mm thick casing for high security installations.
- Internal limits available to co-ordinate with traffic light systems.
- Reliable manual release system, to provide emergency operation in case of mains failure.
- Dark grey paint finish available as an optional extra.



Significant deterrent
for all sizes of vehicle

Adjustable cover plate,
giving a flush fit and
eliminating trip points



Protects against
Ram raids

When quality matters make sure it's SEA
the engineers' choice!

SEA (UK) Limited.
Unit 6A Olton Wharf, Solihull,
West Midlands, B92 7RN
Birmingham Tel: 0121 706 9629
Birmingham Fax: 0121 764 5603
Northern Tel: 0845 837 2830
London Tel: 020 8360 8022
London Fax: 020 8364 2516
sales@seauktd.co.uk
www.seauktd.co.uk



BULL

Specifications

Hydraulic pump capacity
 Standard operating pressure
 Maximum pressure
 Operating temperature
 Hydraulic oil
 Central protection degree
 Rod lowering time
 Rod raising time
 Rod stroke length
 Piston rod diameter
 Max. traction force rod exit
 Max. traction force rod re-entry
 Current supply overall lights (led)
 Current supply
 Absorbed current
 Absorbed power
 Capacitor
 Motor Rotation speed
 Weight of complete system

BULL RISING BOLLARD

4 L/min
 2.2 MPA(22 bar)
 4.5 MPA(35 bar)
 -20°C +55°C
 SEA 0X29
 IP 55
 6 sec.
 8 sec.
 720 mm
 16 mm
 275 Kg
 147 Kg
 24V
 230V- 50 Hz
 2 A
 330 W
 12.5mF
 2800 rpm
 156 kg

CONTROL BOARDS

Technical Specifications

Gate 1 (for 1 Bollards)

- Management of a 230 Vac motor with or without limit switch.
- Automatic logic (4 modes), semiautomatic, step by step logics.
- Electronic slow down in opening and closing.
- Motor run time and pause open regulation.
- Self-learning operating time for gates with limit switches.
- Self-test on photocells.
- Self-diagnostic system.
- Encoder management. (Safety Gate for swing gates)
- Diagnostic Leds on all outputs/inputs.
- Extractable connectors for ease of wiring.
- Integrated receiver compatible with radio transmitters SMART, HEADROLL and HEAD ECOPY series (800 users)
- Fully compatible with all SEA accessories.
- Compatible with most manufactures of audio and video intercom equipment.
- Digital code pads.
- Card reader systems, stand alone and computer linked.
- Time clocks and hold open switches.
- Induction loop free entry, free exit and safety.
- Photocell free entry, free exit and safety.
- Patented rubber mechanical safety edges.
- Vehicle recognition systems.
- Biometric identification systems.



SUPER BULL:
 Heavy duty automatic bollard, with 12mm thick casing.



SOFT:
 New stainless steel fixed bollard for parking and public areas.

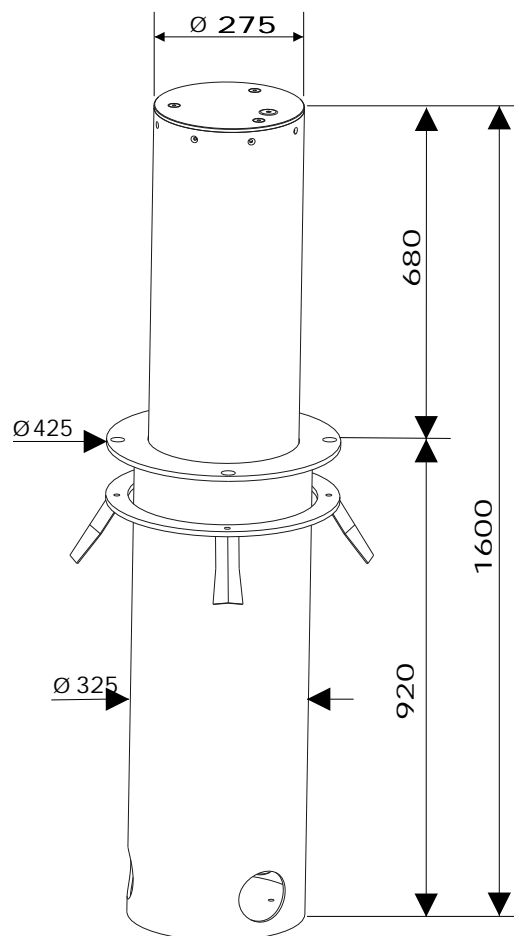

Accessories.

Loop detectors / Photocells / Key pads / Card readers / Transmitters & receivers/ Telephone entry systems / Audio and video intercom systems (wireless or cabled).
 Vehicle recognition systems / Biometric recognition systems / Patented rubber mechanical safety edge / Time clocks / Hold open switches.