



FITTING AND CONNECTION INSTRUCTIONS

The **Compact 200/400/800** consists of a hydraulic pump and a hydraulic jack, both of which coupled in a **supporting box treated with cataphoresis**.

The pump unit casing, which is used as an oil tank, contains the electric motor, fluid pump, distributor and hydraulic oil.

It is also provided with an **adjustable slowing-down device** in the two stop phases of the leaf (versions with slow-down only).

The wheeling unit is composed by a double piston connected to a rack which engages with the pinion of the leaf dragging shaft.

Gates up to 2 meters long can be securely locked using the operators internal hydraulic locking system, thus ensuring perfect keeping in closing and in opening.

For gate in excess of stated value: A hydraulic non locking operator should be used in conjunction with a separate electrical locking device to ensure keeping in closing.

On the operators with hydraulic slow down it is present only during the last 15° of rotation.

The system comes with a release which allows the manual opening of the leaves in case of power failure.

MAIN PARTS NOMENCLATURE

- | | |
|---|-----------------------|
| 1 Braking regulation screw (where provided) | 5 Filling oil Cap |
| 2 Emergency release (authorized staff only) | 6 Water draining hole |
| 3 By-pass regulation | 7 Oil level indicator |
| 4 Exit hole for electric cables | 8 Draining screw |
| | 9 Greaser |
| | 10 Crank |

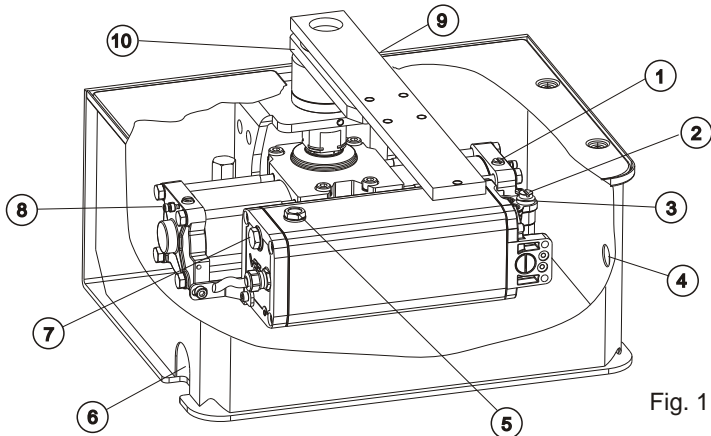
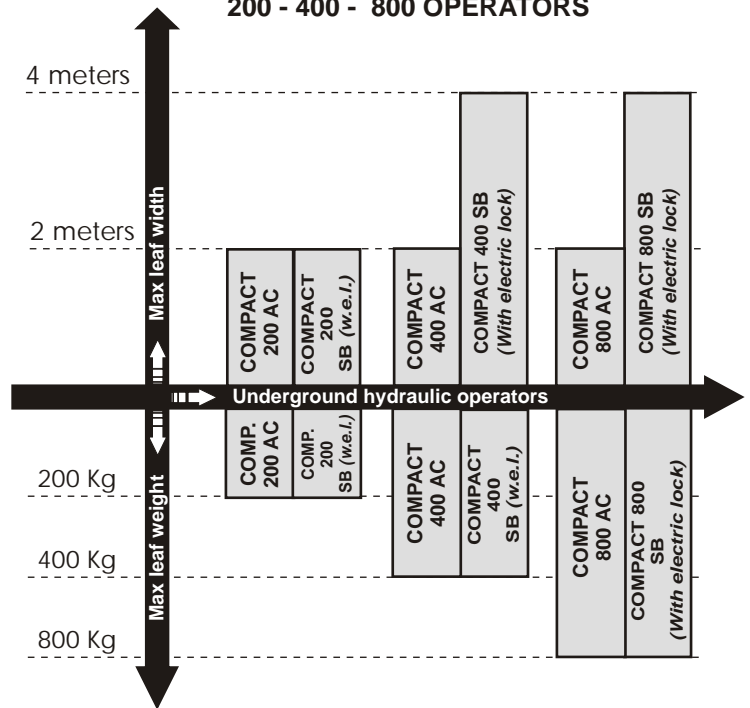

Fig. 1

TECHNICAL DATA	Compact 200	Compact 400	Compact 800
Power supply	230 V (±5%) 50/60 Hz		
Motor Power	200 W	220 W	
Absorbed current	1 A	1,1 A	
Motor rotation speed	1400 rpm		
Cycles hour (with a 20°C temperature)	45		
Max. Working pressure	30 bar	50 bar	
Operating temperature	-20°C +55°C		
Thermal protection intervention	130°C		
Max torque	25 da Nm	56 da Nm	
Starting capacitor	12,5uF		
Weight	12,8 Kg	13 Kg	13,8 Kg
Protection class	IP 67		
Maximum weight of the gate	200 Kg	400 Kg	800 Kg
Braking regulation	On control unit or on operator*		

* In case of operator with hydraulic slow down

GRAPHIC FOR THE USE OF COMPACT 200 - 400 - 800 OPERATORS



Weight Kg GRAPHIC (A)

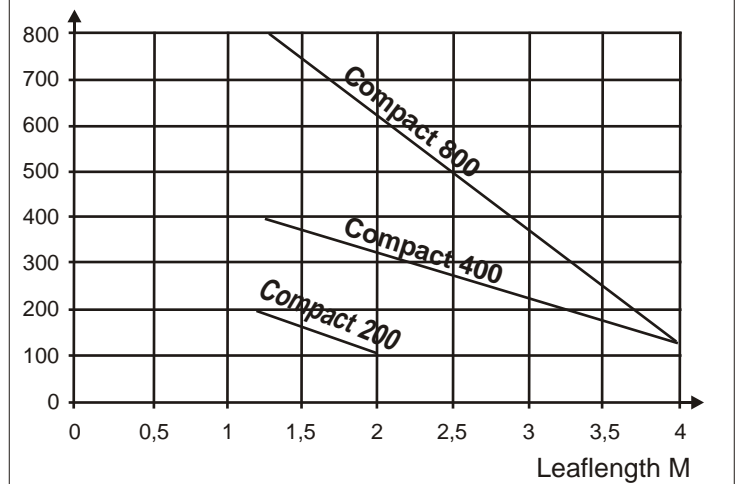

DIMENSIONS (mm)

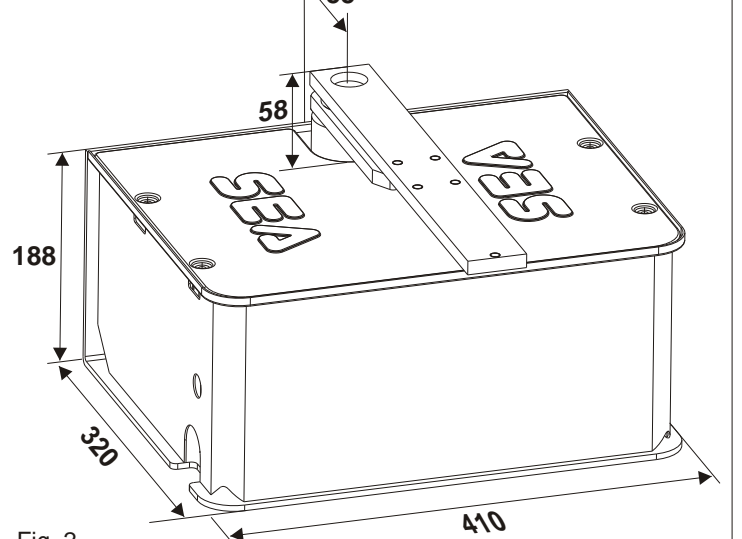

Fig. 2



1. GATE ARRANGEMENT

You must do some checks on the gate to see if fitting a COMPACT system is possible:

- A.** (Make sure that) the fixed and moving parts of the gate are strong and non-deformable;
- B.** the weight of each gate leaf must not exceed 200 Kg (Compact 200), 400 Kg (Compact 400), 800 Kg (Compact 800), see the graphic (A);
- C.** the hinges and general structure must be in good condition and the gate must move smoothly throughout its travel;
- D.** the upper hinge alone is sufficient to install the unit; those which are unnecessary can be eliminated (the lower and that in the middle if exists);
- E.** as the limit switches are not provided within the actuator, it is necessary to install mechanical limit switches stops to be fixed to the ground in closing and in opening (Fig. 3).

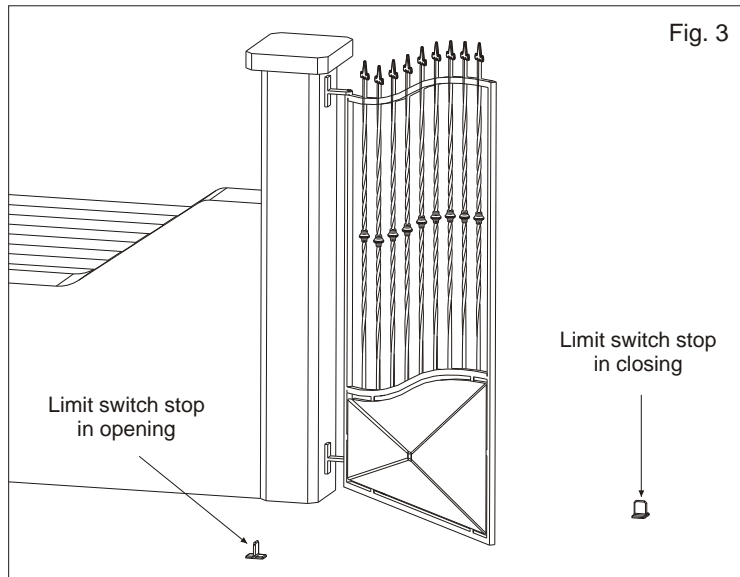

2. CARRYING BOX INSTALLATION

2.1. The hole which contains the carrying box must have the approximate dimensions mentioned in Fig. 4.

For a correct placing, it is obligatory to follow closely the quote of 55 mm which corresponds to the minimum distance of the rotation axis from the pillar.

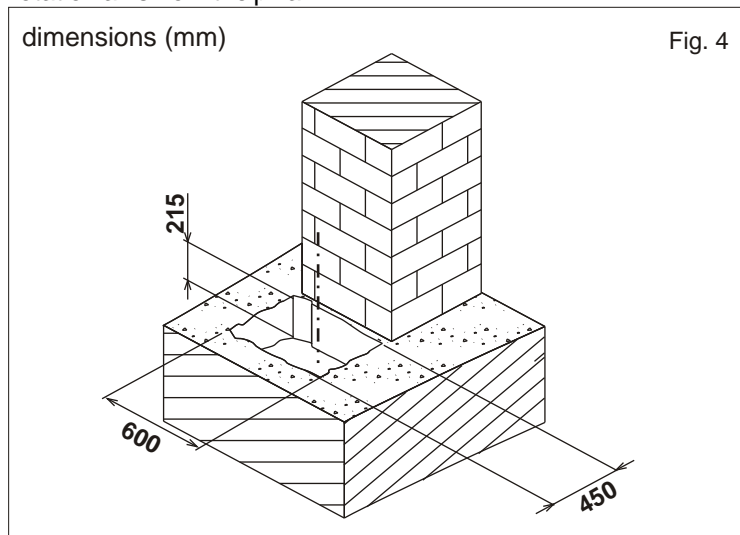

2.2. Inside the excavated pit you have to plan:

- **rain water drainage;**
- a water waste pipe in flexible plastic of about 40 mm of diameter to put inside the provided hole of the box before it is concreted (Fig. 5). **It must be brought until the drain of the sewer line;**
- a sheath for the passage of electrical cables of about 20 mm of diameter which must be brought to the proximity of the electric connection box (Fig. 5).

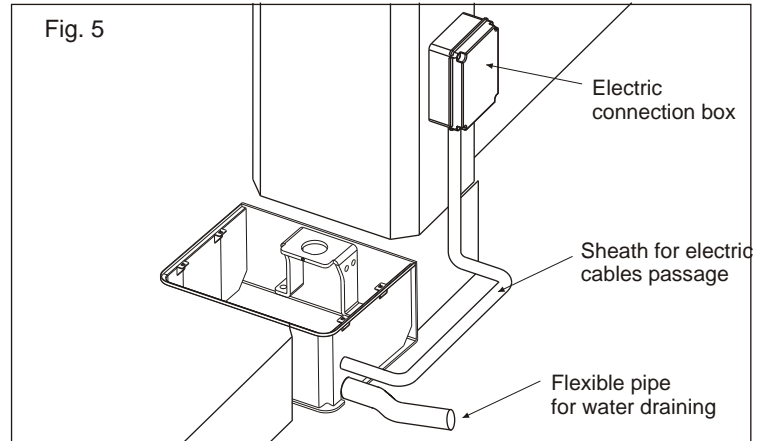

2.3. Before concreting the carrying box, use a level to make it perfectly horizontal to the ground (Fig. 6) and perpendicular to the axis of the gate (Fig. 7).

The axis of the upper hinge of the gate must correspond exactly to the axis of the carrying box shaft.

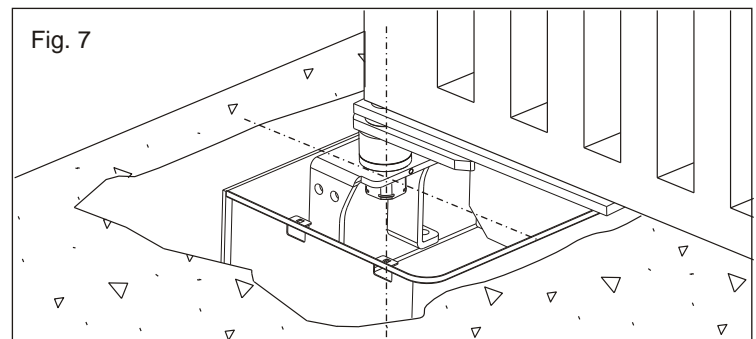
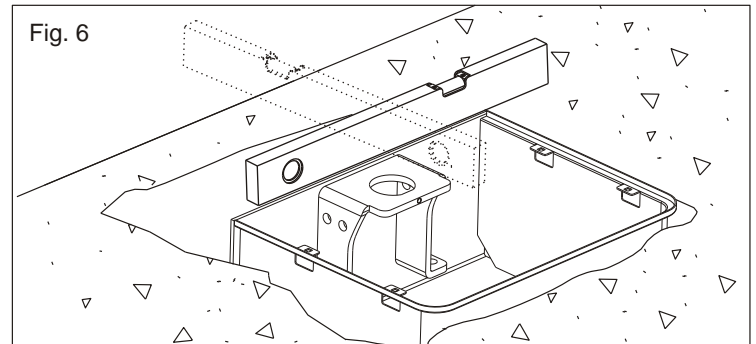

2.4. introduce the buckle of creeping in the box and fix it with the special screws (Fig. 8).

2.5. Insert the units as in Fig. 8.

N.B.: During the insertion of the units lubricate them with the supplied grease.



SEA[®]

Sistemi Elettronici
di Apertura Porte e Cancelli
International registered trademark n. 804888

CE

ENGLISH

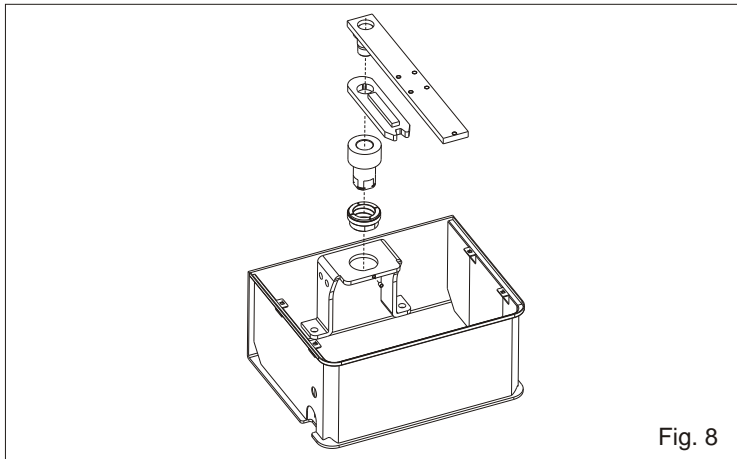

Fig. 8

3. LEAF ASSEMBLING

Before installing the gate make sure that the concrete has hardened into the foundation hole.

3.1. Position the leaf of the gate on the leaf device making reference to the rotation axe of the leaf hinge (Fig. 9);

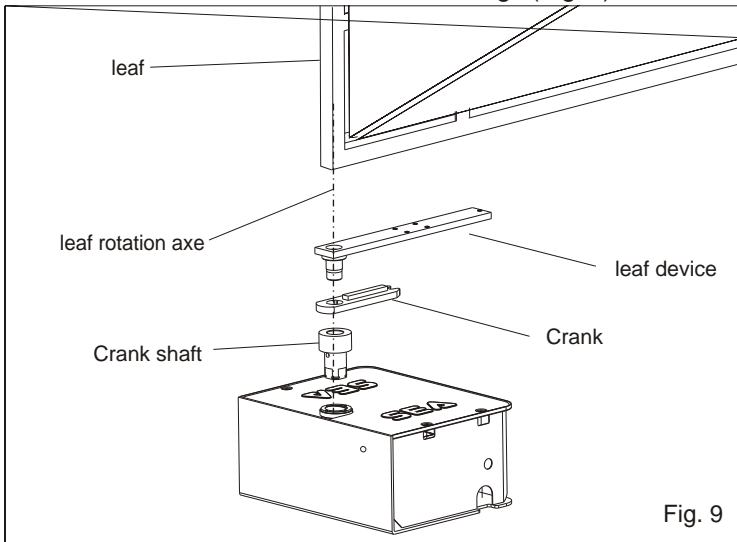

Fig. 9

3.2. Weld with care the leaf device to the leaf of the gate realizing a tract fixation of ca. 3-4 cm along the surface of the contact, avoiding the welding next to the threaded holes, furthermore it is necessary to respect the perpendicularity to the axe of rotation (Fig. 10)

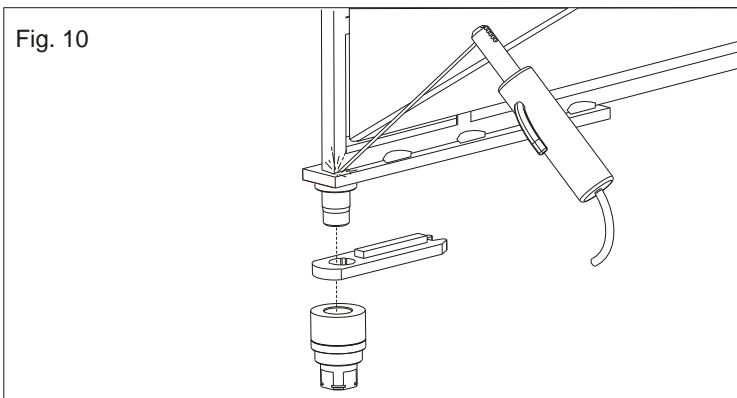

Fig. 10

3.3. Be careful not to place the leaf outside the axis (Fig. 12 and 13), but make sure the shaft corresponds to the hinge rotation axis remembering that the minimum distance from the pillar is 55 mm (Fig. 14).

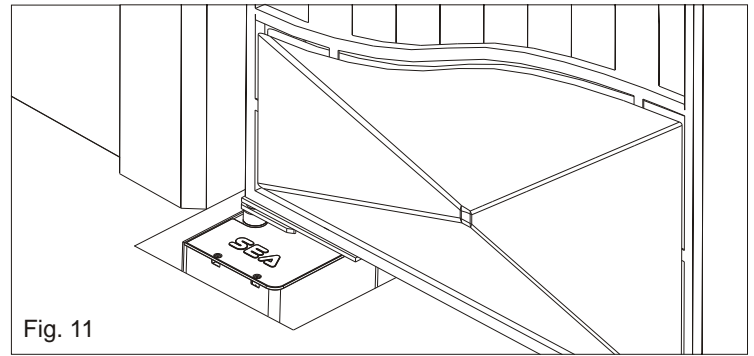

Fig. 11

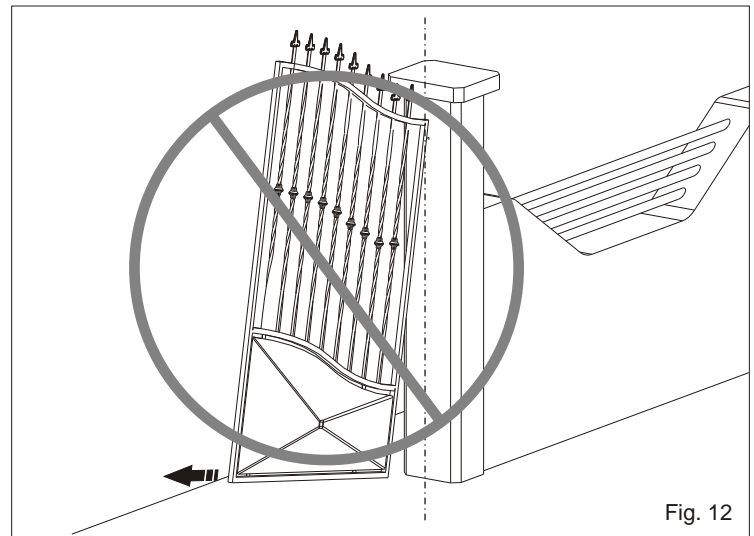

Fig. 12

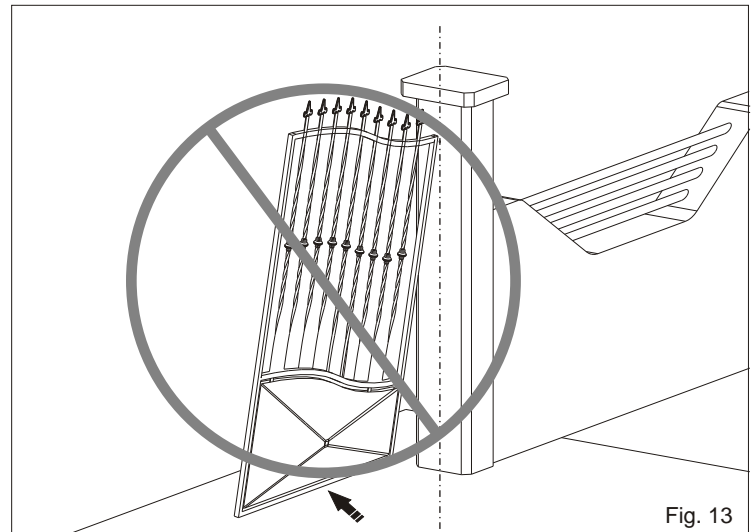

Fig. 13

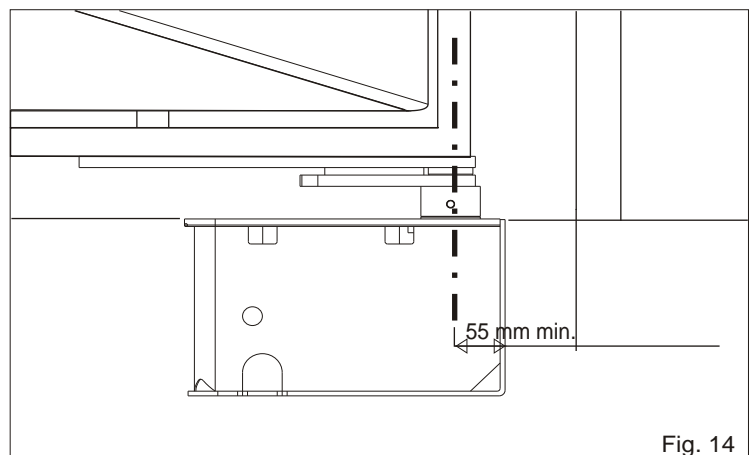

Fig. 14



4. INSTALLATION OF THE OPERATOR

4.1. Insert manually the operator into the carrying box (Fig. 15) also insert the splined shaft of the operator into the splined bush of the box and fix the operator with the special screws as in Fig. 17.

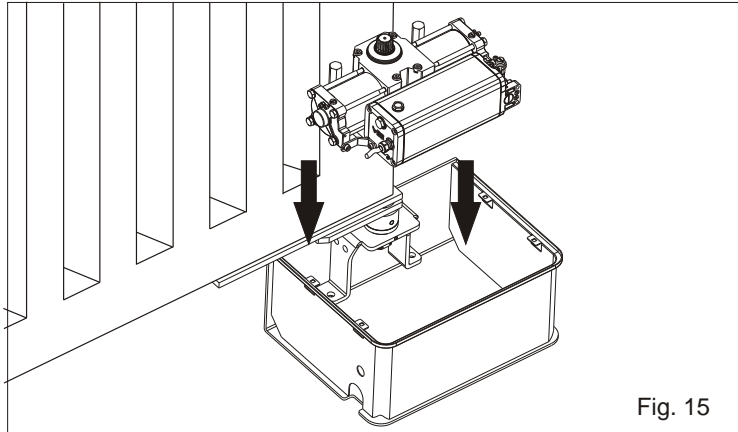

Fig. 15

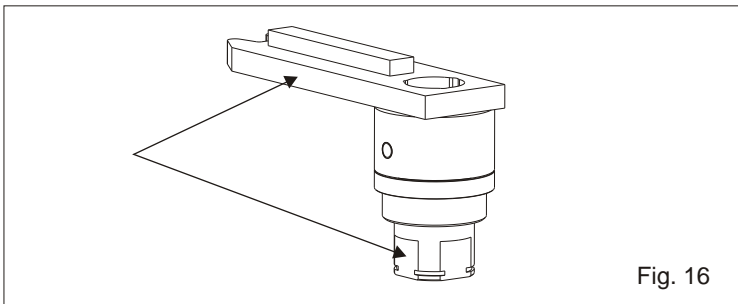

Fig. 16

N.B.: It is advisable to weld the crank with the crank shaft after having also installed the Compact, to use the whole available run and the point of beginning of the desired slowdown (version with hydraulic slowdown).

Before welding, make sure that one of the level of the crank shaft corresponds with a side of the crank (see fig.16 and 17) to guarantee the maximum angle with the mechanical stops Kit.

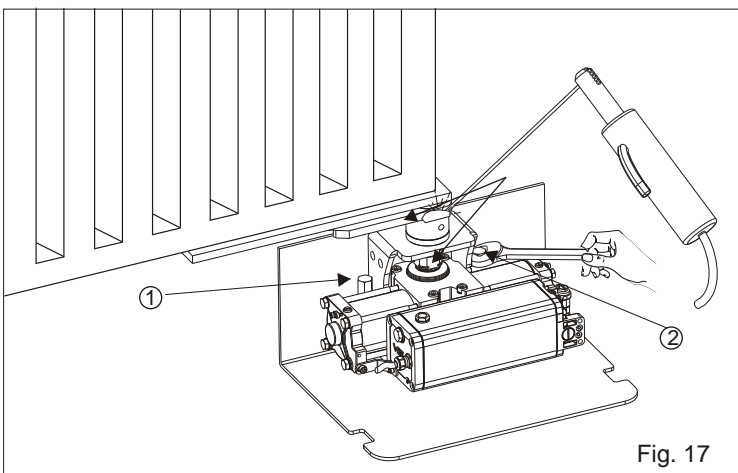

Fig. 17

N.B.: If the Compact is not installed immediately but in a second time, it is recommended to weld the crank shaft and the crank during the installation of the Compact.

4.2. Carry out the electrical connections to the control unit as described in the instructions supplied with SEA control unit.

After ending all the operations in the installation of the above mentioned carrying box, of the gate and the operator, try to do some moves slowly by hand verifying that there are not irregular frictions and that the movement is uniform for the whole range.

Notice: To do this last operation, release the operator as described in the next paragraph.

5. MOTOR RELEASE SYSTEM

5.1. To release act as follows:

-Turn the release screw with the screwdriver about 180° ca. in anti-clockwise direction (Fig. 18).

5.2. To stop again act as follows:

-Turn the release screw with the screwdriver into clockwise direction until it stops.

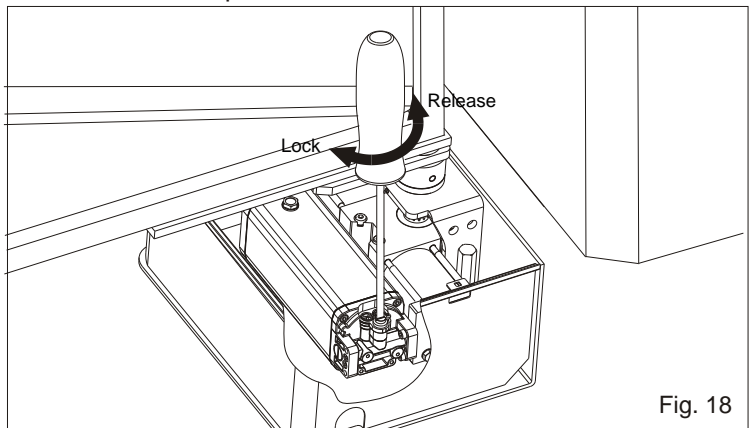

Fig. 18

6. MOUNTING OF THE RELEASE

For the Compact there are foreseen two types of release: **RELEASE** (with personalised key) and **RELEASE PLUS** (with DIN key).

RELEASE

6.1. Grease the hinge (A) and mount the release system under the leaf device using the 4 furnished screws (Fig. 19)

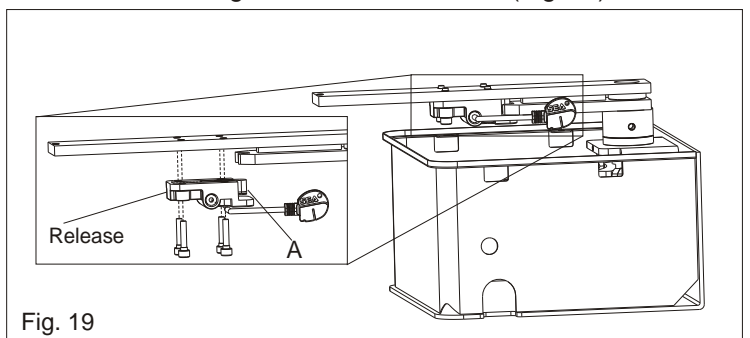

Fig. 19

RELEASE PLUS

6.2. Grease the hinge (A) and mount the release system under the leaf device using the 5 furnished screws (Fig. 20).



SEA®

Sistemi Elettronici
di Apertura Porte e Cancelli
International registered trademark n. 804888

CE

ENGLISH

Fig. 20

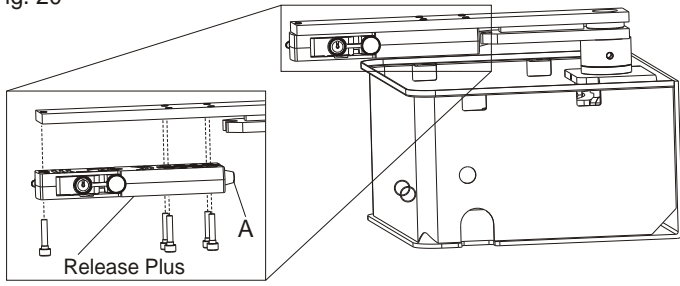

Carry out the electrical connections to the control unit as described in the instructions supplied with SEA control unit.

7. RELEASE SYSTEM OF THE LEAVES

RELEASE

7.1. To release act as follows:

- Insert the enclosed key into the keyhole (S) and turn the handle about 180° against the centre of the gate (Fig. 21).
- Keep the key locked and move the leaf, now turn back the key to the normal position and extract it.

7.2. To stop again act as follows:

- Move the leaf until the lock has coupled again.

Fig. 21

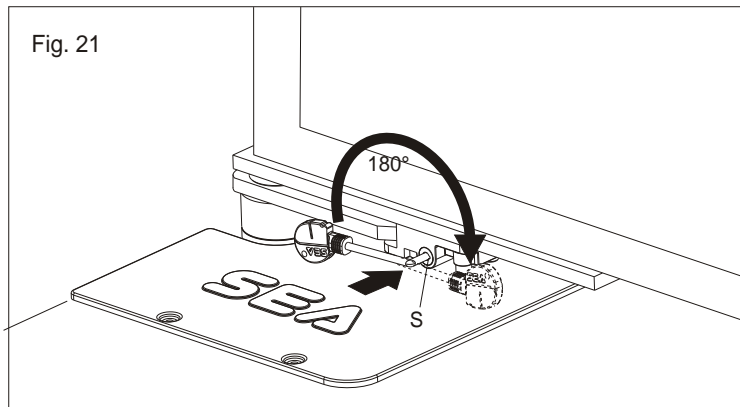

RELEASE PLUS

7.3. To release act as follows:

- Insert the enclosed key into the keyhole and turn it about 90° in clockwise direction (Fig. 22).
- Pull the key against the external of the release making come out the handle of the lock until it reaches the stop (Fig. 23).
- Move the leaf and make return the handle of the release in its original position and extract the key.

7.4. To stop again act as follows:

- Move the leaf until the lock has coupled again.

Fig. 22

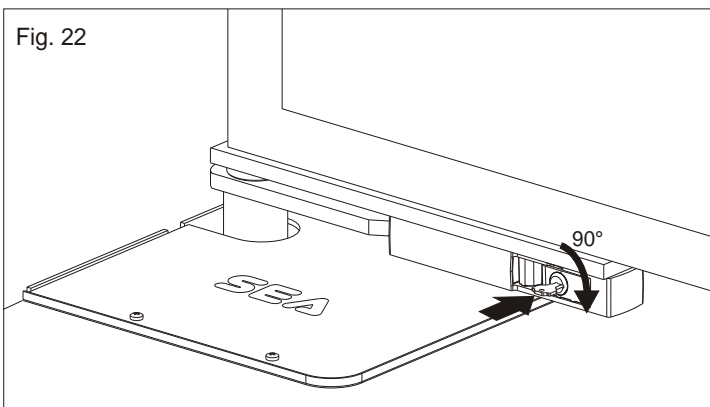
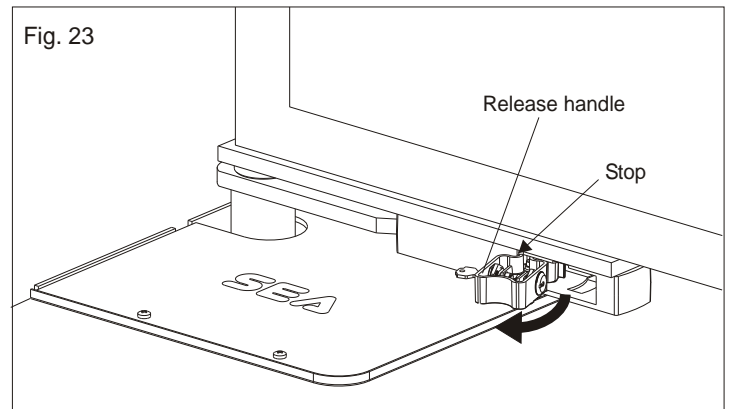

Fig. 23



8. ADJUSTABLE MECHANICAL STOPS

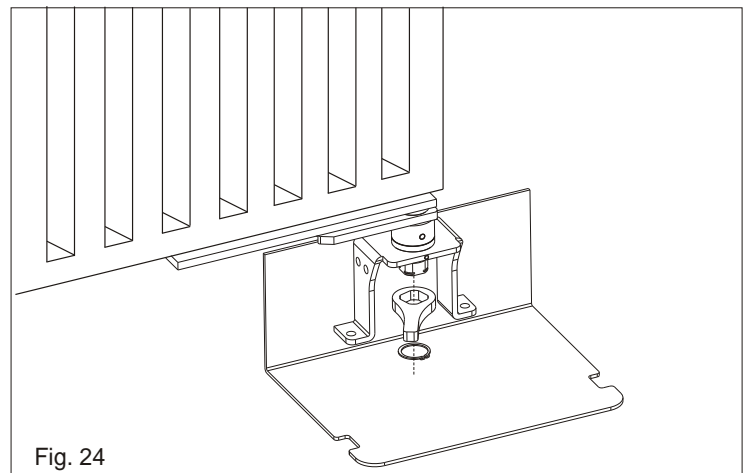

Fig. 24

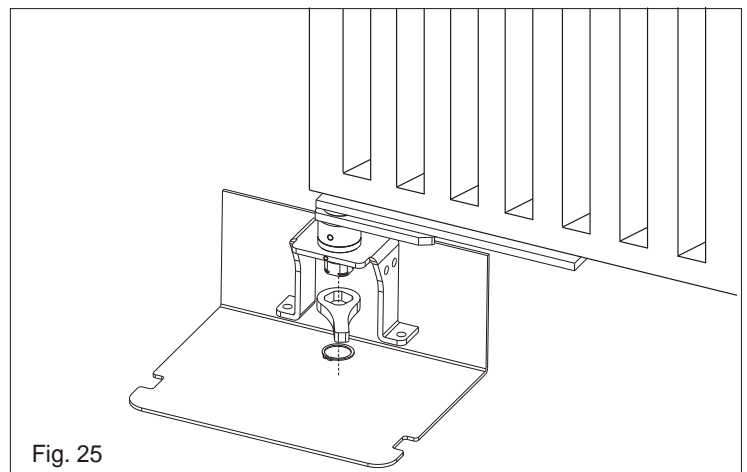

Fig. 25

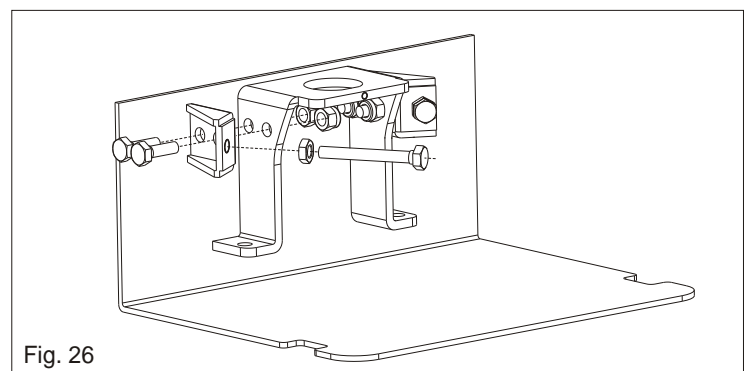

Fig. 26



SEA®

Sistemi Elettronici
di Apertura Porte e Cancelli
International registered trademark n. 804888

CE

ENGLISH

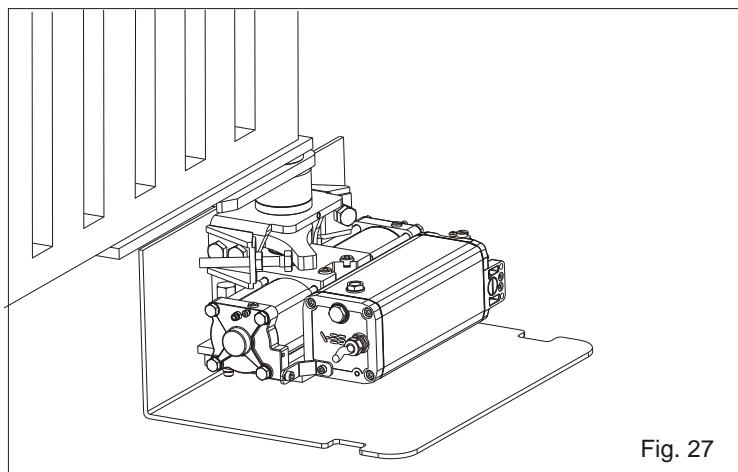

Fig. 27

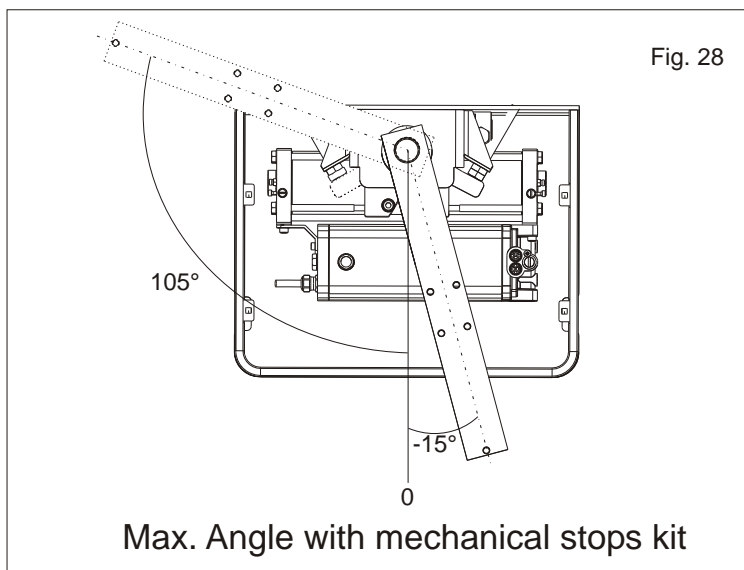

Fig. 28

Max. Angle with mechanical stops kit

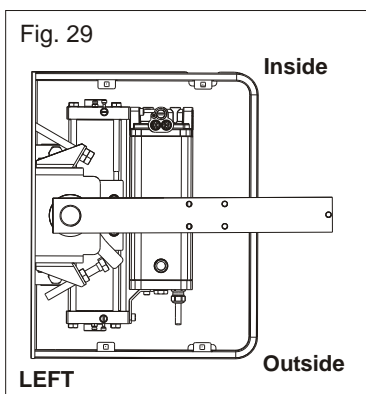

Fig. 29

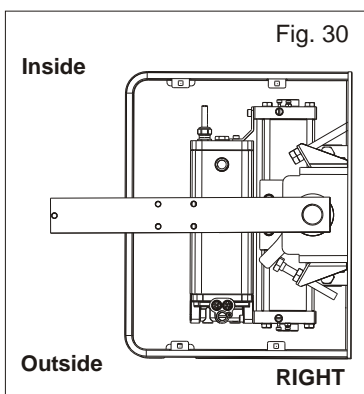

Fig. 30

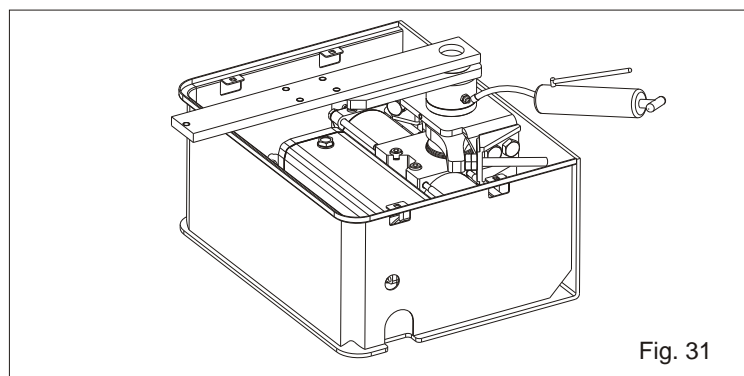

Fig. 31

When putting in function the installation it is peremptory to lubricate the box as in Fig. 31 until the grease comes out. (Use grease type DIN 51502 KP 2 N-20 - K 2 K-20).

67410850

9. REGULATION OF THE PUSHING FORCE

The pushing force or anti-crushing force must be valued by hand or better with a dynamometer and in both the ways of rotation.

To regulate such force act as follow:

act on the by-pass valves with the provided key, given to the authorised installers, clockwise to increase the force, anti-clockwise to decrease it (Fig. 32).

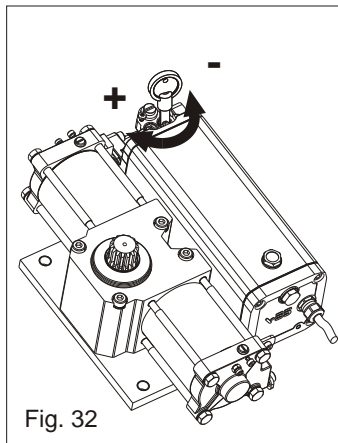

Fig. 32

The adjustment is carried out with the gate moving and will not change the speed of the leaf.

Notice: The maximum regulation is of 15Kgf following the UNI EN 12453 law.

The motor run time is the last adjustment to make. It should be set 2 to 4 seconds higher than it takes to the gate to reach its stop. (this last regulation must be done on the electronic control unit).

10. BRAKING REGULATION (where present)

10.1. It is possible to regulate the leaf slowdown in opening and in closing, through the braking adjusting screw (Fig. 33).

10.2. To regulate slowdown operate as follow:

- Loosen the blocking screw of braking regulation
- Act on the adjusting screw clockwise to have a higher braking and a speed decrease;
- Act on the adjusting screw anti-clockwise to have a lower braking and a speed increase;
- After the regulation fix the blocking screw of braking regulation.

On the operators with hydraulic slow down it is present only during the last 15° of rotation.

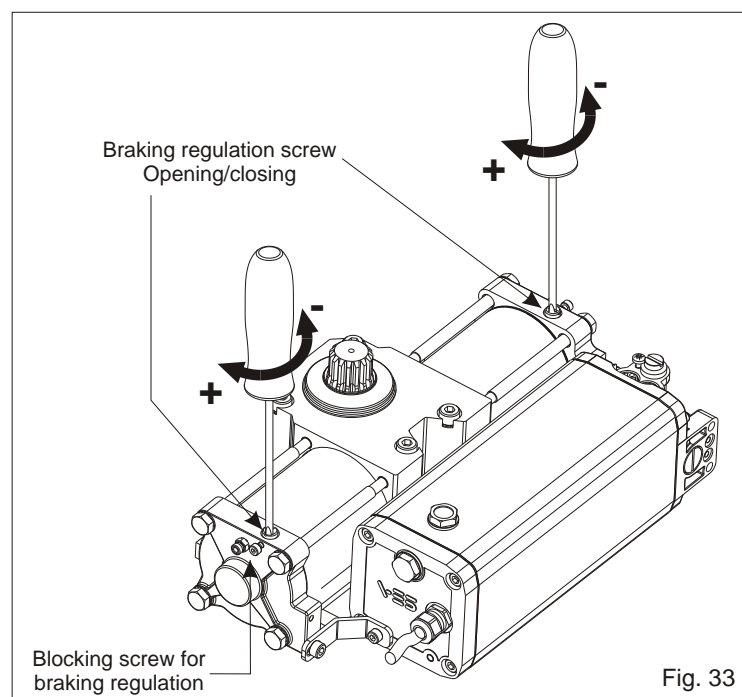

Fig. 33



SEA®

Sistemi Elettronici
di Apertura Porte e Cancelli
International registered trademark n. 804888

CE

ENGLISH

11. CABLE LAYOUT (Fig. 34)

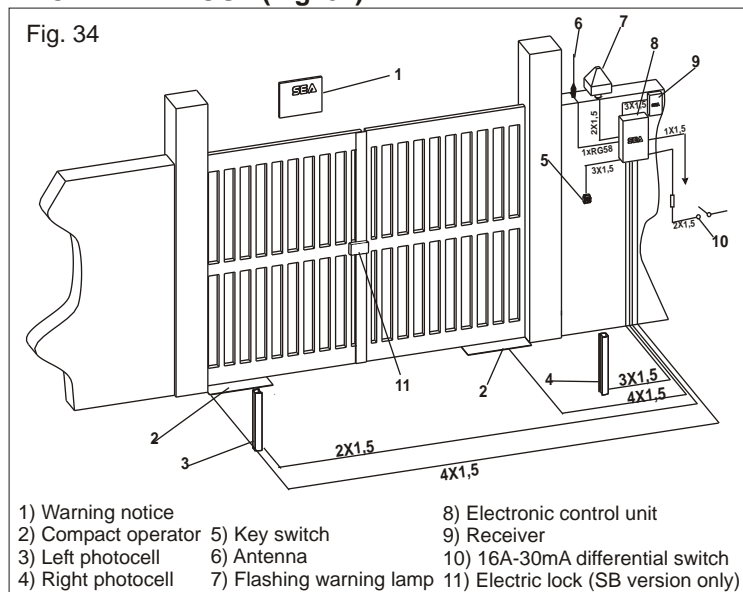

12. RISK EXAMINATION

The points pointed by arrows in Fig. 35 are potentially dangerous. The installer must take a thorough risk examination to prevent crushing, conveying, cutting, grappling, trapping so as to guarantee a safe installation for people, things and animals (Re. Laws in force in the country where installation has been made.).

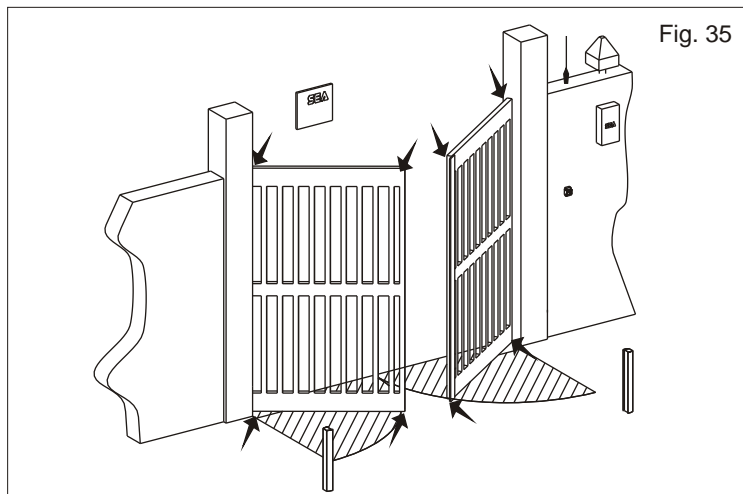

NOTICE

As for misunderstandings that may arise refer to your area distributor or call our help desk. These instructions are part of the device and must be kept in a well known place. The installer shall follow the provided instructions thoroughly. SEA products must only be used to automate doors, gates and wings. Any initiative taken without SEA Srl explicit authorization will preserve the manufacturer from whatsoever responsibility. The installer shall provide warning notices on not assessable further risks. SEA s.r.l. in its relentless aim to improve the products, is allowed to make whatsoever adjustment without giving notice. This doesn't oblige Sea to up-grade the past production. SEA s.r.l. can not be deemed responsible for any damage or accident caused by product breaking, being damages or accidents due to a failure to comply with the instructions herein. The guarantee will be void and the manufacturer responsibility (according to Machine Law) will be nullified if SEA Srl original spare parts are not being used.

The electrical installation shall be carried out by a professional technician who will release documentation as requested by the laws in force. This is a quotation from the GENERAL DIRECTIONS that the installer must read carefully before installing. Packaging materials such as plastic bags, foam polystyrene, nails etc must be kept out of children's reach as dangers may arise.

SAFETY GATE

For a correct and safe installation it is strongly recommended to install a Safety Gate, which allows the fulfilment of the force diagram included in the norm EN 12453 and consequently the test and start of the whole installation.

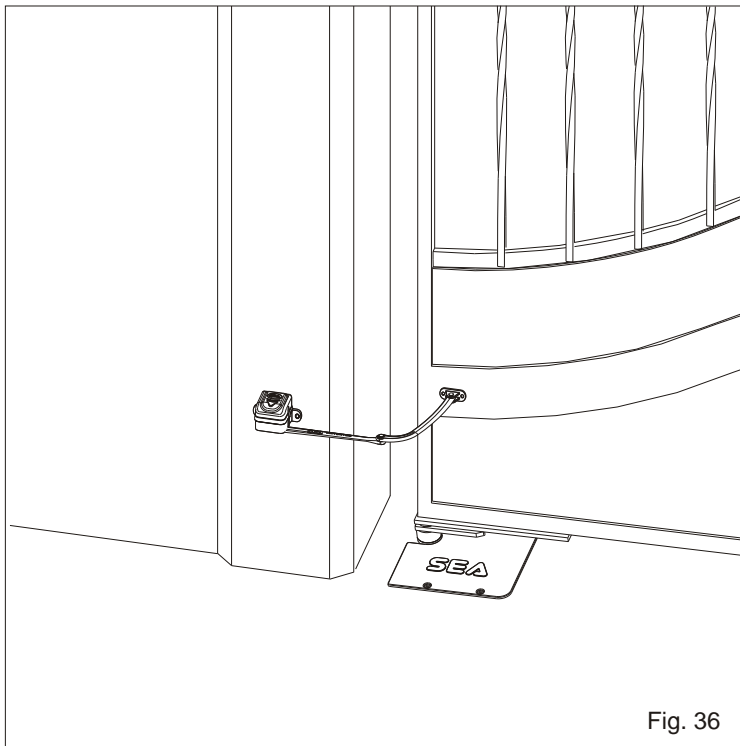

PERIODICAL MAINTENANCE

Check the oil level (Trasparent cap n.7 in Fig. 1)	Annual
Change the oil	4 years
Verify the functionality of the by-pass valves (check the force in opening and closing)	Annual
Check the release function	Annual
Verify the slowdown regulation (where present)	Annual
Check the correct drain of the rainwater	Annual
Check the integrity of the connection cables	Annual
Grease all the moving parts	Annual
Grease the rotation axis of the box as in Fig.31	Annual

All the above described operations must be made exclusively by an authorized installer.



ACCESSORIES FOR COMPACT



CARRYING BOX INOX



RELEASE

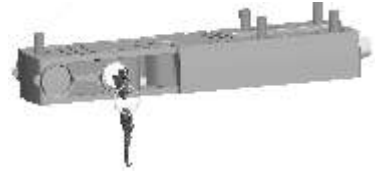

RELEASE PLUS

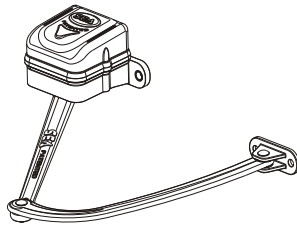

SAFETY GATE



KIT MECHANICAL STOP

DECLARATION OF CONFORMITY

SEA declares under its responsibility that the products

Compact 200, Compact 400, Compact 800

meet the essential requisites provided for by the following European Directive and following changes:

89/392/CEE (Machine Directive)

89/336/CEE (Electromagnetic Compatibility Directive)

73/23/CEE (Low Tension Directive)

SAFETY PRECAUTIONS:

All electrical work should conform to current regulations. A 16 A 0,030 A differential switch must be incorporated into the source of the operators main electrical supply and the entire system properly earth bonded. Always run mains carrying cables in separate ducts to low voltage control cables to prevent mains interference.

INTENDED USE:

Compact 200, Compact 400 and Compact 800 undergrounded operators have been designed to be used only for the automation of swing gates.

SPARE PARTS:

To obtain spare parts contact:

SEA s.r.l. - Zona Ind.le, 64020 S. ATTO Teramo Italia

SAFETY AND ENVIRONMENTAL COMPATIBILITY:

Don't waste product packing materials and/or circuits.

When being transported this product must be properly packaged and handled with care.

MAINTENANCE AND OUT OF SERVICE:

The decommission and maintenance of this unit must only be carried out by specialised and authorised personnel.

NOTE: THE MANUFACTURER CAN NOT BE DEEMED RESPONSIBLE FOR ANY DAMAGE OR INJURY CAUSED BY IMPROPER USE OF THIS PRODUCT.

SEA reserves the right to do changes or variations that may be necessary to its products with no obligation to notice.



TERMS OF SALE

EFFICACY OF THE FOLLOWING TERMS OF SALE: The following general terms of sale shall be applied to all orders sent to SEA srl. All sales made by SEA to all customers are made under the prescription of this terms of sales which are integral part of the sale contract and cancel and substitute all opposed clauses or specific negotiations present in the order or in other documents received from the buyer.

GENERAL NOTICE The gate automation systems must be assembled exclusively with SEA components, unless specific agreements apply. Non-compliance with the applicable safety standards (European Standards EN 12453 EN12445 and others) and with good installation practice releases SEA from any responsibilities. SEA shall not be held responsible for any failure to execute a correct and safe installation under the above mentioned standards.

1) PROPOSED ORDER The proposed order shall be accepted only prior SEA approval of it. By signing the proposed order, the Buyer shall be bound to enter a purchase agreement, according to the specifications stated in the proposed order and always under those Terms of sale. On the other hand, failure to notify the Buyer of said approval must not be construed as automatic acceptance on the part of SEA.

2) PERIOD OF THE OFFER The offer proposed by SEA or by its branch sales department shall be valid for 30 solar days, unless otherwise notified.

3) PRICING The prices in the proposed order are quoted from the Price List which is valid on the date the order was issued. The discounts granted by the branch sales department of SEA shall apply only prior to acceptance on the part of SEA. The prices are for merchandise delivered ex-works from the SEA establishment in Teramo, not including VAT and special packaging. SEA reserves the right to change at any time this price list, providing timely notice to the sales network.

4) PAYMENTS The accepted forms of payment are each time notified or approved by SEA. The interest rate on delay in payment shall be 1.5% every month but anyway shall not be higher than the max. interest rate legally permitted.

5) DELIVERY Delivery shall take place, approximately and not peremptorily, within 30 working days from the date of receipt of the order, unless otherwise notified. Transport of the goods sold shall be at Buyer's cost and risk. SEA shall not bear the costs of delivery giving the goods to the carrier, as chosen either by SEA or by the Buyer. Any loss and/or damage of the goods during transport, are at Buyer's cost.

6) COMPLAINTS Any complaints and/or claims shall be sent to SEA within 8 solar days from receipt of the goods, proved by adequate supporting documents as to their truthfulness.

7) SUPPLY The concerning order will be accepted by SEA without any engagement and subordinately to the possibility to get its supplies of raw material which is necessary for the production; Eventual completely or partially unsuccessful executions cannot be reason for complains or reservations for damage. SEA supply is strictly limited to the goods of its manufacturing, not including assembly, installation and testing. SEA, therefore, disclaims any responsibility for damage deriving, also to third parties, from noncompliance of safety standards and good practice during installation and use of the purchased products.

8) WARRANTY.

SILVER: The mechanical components of the operators belonging to this line are guaranteed for 24 months from the date of manufacturing written on the operator.

GOLD: The mechanical components of the operators belonging to this line are guaranteed for 36 months from the date of manufacturing written on the operator.

PLATINUM: The mechanical components of the operators belonging to this line are guaranteed for 36 months from the date of manufacturing written on the operator. The base warranty (36 months) will be extended for further 24 months (up to a total of 60 months) when it is acquired the certificate of warranty which will be filled in and sent to SEA s.r.l. within 30 days from the purchase date. The electronic devices and the systems of command are guaranteed for 24 months from the date of manufacturing. In case of defective product, SEA undertakes to replace free of charge or to repair the goods provided that they are returned to SEA repair centre.

The definition of warranty status is by unquestionable assessment of SEA. The replaced parts shall remain propriety of SEA. Binding upon the parties, the material held in warranty by the Buyer, must be sent back to SEA repair centre with fees prepaid, and shall be dispatched by SEA with carriage forward. The warranty shall not cover any required labour activities. The recognized defects, whatever their nature, shall not produce any responsibility and/or damage claim on the part of the Buyer against SEA. The guarantee is in no case recognized if changes are made to the goods, or in the case of improper use, or in the case of tampering or improper installation, or if the product label of the manufacturer with the registered SEA trademark n° 804888 has been removed. Furthermore, the warranty shall not apply if SEA products are partly or completely coupled with non-original mechanical and/or electronic components, and in particular, without a specific relevant authorization, and if the Buyer is not making regular payments. The warranty shall not cover damage caused by transport, expendable material, faults due to non-conformity with performance specifications of the products shown in the price list. No indemnification is granted during repairing and/or replacing of the goods in warranty. SEA disclaims any responsibility for damage to objects and persons deriving from non-compliance with safety standards, installation instructions or use of sold goods. The repairs of products in warranty and out of warranty is accepted only if the procedure of SEA are fully respected by the customer.

9) RESERVED DOMAIN A clause of reserved domain applies to the sold goods; SEA shall decide autonomously whether to make use of it or not, whereby the Buyer acquires the property of the goods only after full payment of the invoice.

10) COMPETENT COURT OF LAW In case of disputes arising from the application of the agreement, the competent court of law is the tribunal of Teramo. The official language for the interpretation of the catalogue, the manuals, the terms of sale and any other is the italian language. SEA reserves the faculty to make technical changes to improve its own products, which are not in this price list at any moment and without notice.

SEA declines any responsibility due to possible mistakes contained inside the present price list caused by printing and/or copying. The present price list cancels and substitutes the previous ones. The Buyer, according to the law No. 196/2003 (privacy code) consents to put his personal data, deriving from the present contract, in SEA archives and electronic files, and he also gives his consent to their treatment for commercial and administrative purposes.

Industrial ownership rights: with the purchase, the buyer accepts in full the present Terms of Sale and recognizes that SEA has the exclusive legal ownership of the registered SEA International trademark n° 804888 which is attached on each products label, and/or on manuals, packaging and/or in any other documentation, and he will commit himself to use it in its marketing and/or installation activity in a way which does not reduce the value of these rights; he won't also remove, replace or modify the trademark or any other particularity from the products. Any kind of replication or use of SEA brand is forbidden as well as of any change of sings-brands on the products, unless preventive and expressed authorization by SEA.